

Trasa: RYBNIK - JEJKOWICE - LYSKI



**MCJ**<sup>®</sup>  
*Oświetlenie*

**MCJ**  
ul. Sumińska 2a  
44-293 Gaszowice (Szczerbice)  
tel: +48/32/423 45 44  
tel: +48/32/422 92 63  
fax: +48/32/423 92 86  
katalog: [www.mcj.pl](http://www.mcj.pl)  
adres e-mail: [mcj@mcj.pl](mailto:mcj@mcj.pl)



**W ofercie także BLOKOMINKI**



**KOMINEK BEZ KOMINA**



2009-2010

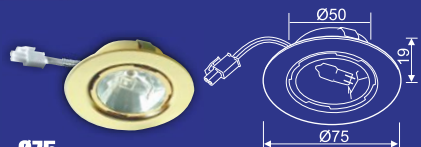

**Ø75**

NR		S
7520-1/...	G4 1x max 20W/12V	PI

**LED 75LED/...** | LED 1,4W/12V DC | PI

**G4 LED** U. Pat. RU 63958



szkło piaskowane sand-blasted Sandgestrahltes матовое стекло



**Ø65**

NR		S
6520-1/...	G4 1x max 20W/12V	PI

**LED 65LED/...** | LED 1,4W/12V DC | PI

**G4 LED** U. Pat. RU 63958



**Ø84S**

NR	
84S/...	Micro-Lynx F 1x max 7W/230V

**LED 84SLED/...** | LED 1,4W/12V DC | PI

**G4 LED** U. Pat. RU 63958

230V/50Hz

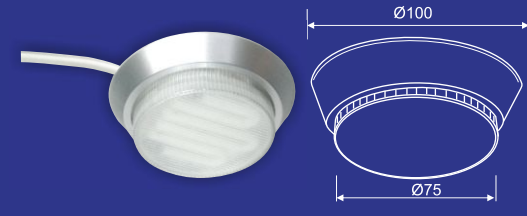

**Ø84SDY**

NR	
84SDY/...	Micro-Lynx F 1x max 7W/230V

**LED 84SDYLED/...** | LED 1,4W/12V DC | PI

**G4 LED** U. Pat. RU 63958

230V/50Hz



**K65**

NR		S
K6520-1/...	G4 1x max 20W/12V	PI

**LED K65LED/...** | LED 1,4W/12V DC | PI

**G4 LED** U. Pat. RU 63958



**Ø65DY**

NR		S
65DY20-1/...	G4 1x max 20W/12V	PI

**LED 65DYLED/...** | LED 1,4W/12V DC | PI

**G4 LED** U. Pat. RU 63958



**Ø68**

NR		S
68R/...	G4 1x max 20W/12V	PR

**LED 68RLED/...** | LED 1,4W/12V DC | PR

**G4 LED** U. Pat. RU 63958



**C:** -kolory/ colours/ Farben/ цвета

CH	chrom/chrome/хром/хром
AL	aluminium/алюминий
AN	antyk/antique/antik/антик
SA	satyna/satin/nickel mat/сатин
ZL	zloto/gold/золото
ST	stal drapana/scratched steel/ Stahl gebuerstet/сталь

**NR** – nr kat. • cat.nr • Art.Nr • № в каталоге

**S** – rodzaj szkła • glass type • Glas • вид стекла

– żarówka • bulb • Leuchtmittel • лампочка

**PI** – piaskowane • sand blasted • Sandgestrahlt • матовое

**PR** – przezroczyste • transparent • Klar • прозрачное

**G4** – żarówka G4 20W/12V, komplet z kablem dł. 15 cm z wtykiem AMP  
 - bulb G4 20W/12V, set includes 15 cm cable with AMP plug  
 - Leuchtmittel G4 20W/12V, Komplett mit 15 cm Kabel und AMP Kontakt  
 - лампочка G4 20Вт./12V, комплект с кабелем длиной 15 см. с соединителем AMP

**LED** – możliwe źródło światła LED G4 1,4W/12V DC, komplet z kablem dł. 2m z wtykiem  
 - possibility of using the LED lamp G4 1.4W/12V DC, set includes 2m cable, with plug  
 - möglichkeit des Anwenden die Leuchtmittel LED G4 1.4W/12V DC, Komplett mit 2m Kabel und Kontakt  
 - возможный источник света LED лампочка G4 1,4Вт./12V DC, в комплекте с кабелем длиной 2м. с соединителем



Zestaw może zawierać oprawy: **Ø75 Ø65 Ø65DY K65 Ø68**  
**LED Zestaw może zawierać oprawy: Ø75 Ø65 Ø65DY K65 Ø68**



**Ø75**

NR	IL	C:
Z01-75/...	1	-CH
Z02-75/...	2	-AL
Z03-75/...	3	-SA
Z04-75/...	4	-ZL
Z05-75/...	5	-ST

**Ø75 LED**

NR	IL	C:
<b>LED</b> Z01-75LED/...	1	-CH
<b>LED</b> Z02-75LED/...	2	-AL
<b>LED</b> Z03-75LED/...	3	-SA
<b>LED</b> Z04-75LED/...	4	-ZL
<b>LED</b> Z05-75LED/...	5	-AN

**C:**

-CH  
-AL  
-SA  
-ZL  
-ST  
-AN

**LED**

- szkło piaskowane lub przezroczyste, żarówka G4 10 lub 20W/12V, system AMP
- sand-blasted or transparent glass, bulb G4 10 or 20W/12V, AMP system
- Sandgestrahltes oder klares Glas, Leuchtmittel G4 10 oder 20W/12V, AMP Systeme
- стекло матовое или прозрачное, лампочка G4 10 или 20Вт./12V, система AMP

**LED** - możliwe źródło światła LED G4 1,4W/12V DC.  
 - possibility of using the LED lamp G4 1.4W/12V DC.  
 - möglichkeit des Anwenden die Leuchtmittel LED G4 1.4W/12V DC.  
 - возможный источник света LED лампочка G4 1,4Вт./12V DC

- W skład zestawu wchodzi:
- oprawy wraz z żarówkami (od 1 do 5 szt.)
  - transformator odpowiedni do potrzebnej mocy
  - kabel zasilający z eurowtykiem długości 2m.
  - rozdzielacz AMP.

Set includes:  
 - luminaires with bulbs (from 1 to 5 pcs)  
 - transformer adequate to used power  
 - feeder cable with Euro plug 2m  
 - AMP adapter

Packungsinhalt:  
 - Strahler mit Leuchtmittel ( 1 bis 5 Stck.)  
 - Trafo  
 - Anschlusskabel 2m lang  
 - AMP-Verteiler

- В комплект входит:
- светильники вместе с лампочками (с 1 до 5 шт.)
  - трансформатор
  - кабель с евровилкой 2м.
  - соединитель AMP

**W skład zestawu LED wchodzi:**  
 - (1- 5) x oprawa LED G4 1,4W/12V DC, LED w każdej z opraw  
 - Zasilacz napięcia stałego 12V/8W.  
 - Rozdzielacz  
 - Kabel sieciowy o długości 1,75m z wyłącznikiem.

Set includes:  
 - (1-5) x LED light G4 1,4W/12V DC, LED's in each light.  
 - adapter  
 - Electronic power supply 12V/8W.  
 - Feeder cable with switch 1,75m.

Inkl:  
 - (1-5) x LED Leuchten G4 1,4W/12V DC, pro Stück  
 - elektron. Trafo 12V/8W.  
 - Verteiler  
 - Eingang mit 1,75m. Zuleitung und Zwischenschalter

В комплект LED входит:  
 - (1-5) шт. светильников LED G4 1,4Вт./12V DC, LED в каждом светильнике  
 - источник питания постоянного напряжения  
 - разделитель  
 - сетевой кабель длн. 1,75м. с выключателем

**C:** -kolory/ colours/ Farben/ цвета

CH	chrom/chrome/chrom/хром
AL	aluminium/алюминий
AN	antyk/antique/antik/антик
SA	satyna/satin/nickel mat /латин
ZL	złoto/gold/золото
ST	stal drapana/scratched steel/ Stahl gebuerstet/сталь

**NR** - nr kat. • cat.nr • Art.Nr • № в каталоге  
**IL** - ilość • quantity • Menge • количество

NR	IL	KS
Z0L3-15BI	3	BI
Z0L3-15NI	3	NI
Z0L5-15BI	5	BI
Z0L5-15NI	5	NI

U. Pat. RU 63936

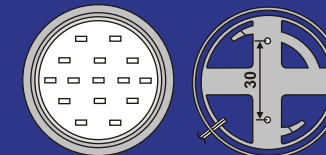

IP20 CE 230V/50Hz

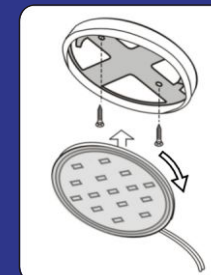

-kolory/ colours/ Farben/ цвет



aluminium aluminium  
 chrom chrome  
 chrom chrome  
 biały white  
 white weiss  
 белый белый

Komplet zawiera:  
 - (3 lub 5) x oprawa LED 12V 1W; 2m przewód, 15 LED w każdej z opraw  
 - Zasilacz napięcia stałego 12V/8W.  
 - Rozdzielacz do podłączenia opraw (4-5).  
 - Kabel sieciowy o długości 1,75m z wyłącznikiem.  
 - Kolor światła: biały, niebieski.  
 - Ramki do opraw w 3 kolorach : aluminium, chrom, biały.

Set includes:  
 - (3 or 5) x LED light 12V 1W, 2m cable, 15 LED's in each light.  
 - Electronic power supply 12V/8W.  
 - Adapter for lights (4-5) .  
 - Feeder cable with switch 1,75m.  
 - Light colour: white, blue.  
 - Cases for lights in 3 different colours: aluminium, chrome, white.

Inkl:  
 - (3 oder 5) x LED Leuchten 12V 1W, pro Stück 15 fig, 2m Zuleitung  
 - elektron. Trafo 12V/8W.  
 - Kabelverteiler (4-5).  
 - Eingang mit 1,75m. Zuleitung und Zwischenschalter  
 - Lichtfarbe: weiss, blau.  
 - Ringe in 3 Farben: aluminium, chrome, weiss.

В комплект входит:  
 - (3 – 5 шт.) светильников LED 12V 1Вт.; 2 м. провод, 15 LED в каждом светильнике  
 - источник питания постоянного напряжения  
 - разделитель для подключения светильников (4-5 шт.)  
 - сетевой кабель 1,75м. с выключателем  
 - цвет свечения: белый, голубой (синий)  
 - оправы для светильников в трех цветах: алюминий, хром, белый.



**NR** - nr kat. • cat.nr • Art.Nr • № в каталоге  
**IL** - ilość • quantity • Menge • количество  
**KS** - kolor światła • light colour • Licht Farben • цвет свечения  
**BI** - biały • white • weiss • белый  
**NI** - niebieski • blue • blau • голубой/синий

Schemat łączenia

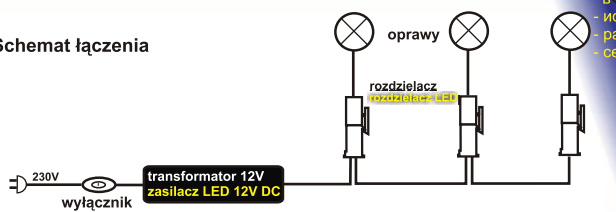

IP20 CE 230V/50Hz

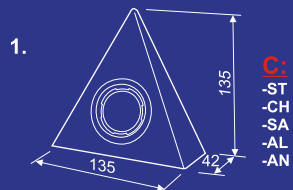

trójkąt/ triangle/ Dreieck/ треугольник

NR	
TR/...	G4 1x max 20W/12V
LED TRLED/...	LED 1,4W/12V DC

**G4 LED** U. Pat. RU 63938

szkło piaskowane sand-blasted Sandgestrahltes матовое стекло

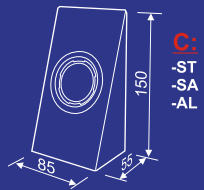

klin/ wedge/ Keil/ прямоугольник

NR	
KL/...	G4 1x max 20W/12V
LED KLLED/...	LED 1,4W/12V DC

**G4 LED** U. Pat. RU 63943



U. Pat. RU 63682

tezka/ tear/ Träne/ полусфера

NR	
LE/...	G4 1x max 20W/12V
LED LELED/...	LED 1,4W/12V DC

**G4 LED**

szkło piaskowane sand-blasted Sandgestrahltes матовое стекло

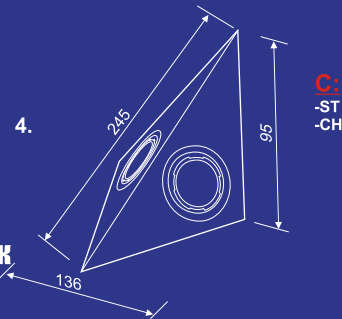

trójkąt rogowy  
corner triangle  
Eckleuchte Dreieck  
роговой треугольник

NR	
TRR/...	G4 2x max 20W/12V
LED TRRLED/...	LED 2x 1,4W/12V DC

**G4 LED**



**C:** -kolory/ colours/ Farben/ цвета

CH	chrom/chrome/хром/хром
AL	aluminium/алюминий
AN	antyk/antique/antik/антик
SA	satyna/satin/nickel mat/сатин
ZL	złoto/gold/золото
ST	stal drapana/scratched steel/ Stahl gebuerstet/сталь

NR = nr kat. • cat.nr • Art.Nr • № в каталоге

= żarówka • bulb • Leuchtmittel • лампочка

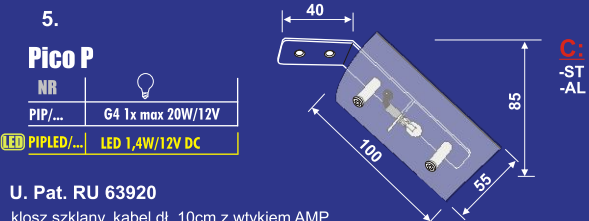

Pico P

NR	
PIP/...	G4 1x max 20W/12V
LED PIPLD/...	LED 1,4W/12V DC

U. Pat. RU 63920

klosz szklany, kabel dł. 10cm z wtykiem AMP  
glass lampshades, set includes 10 cm cable with AMP plug  
Glasschirm, mit 10cm Kabel und AMP Kontakt  
стеклянный плафон с кабелем длиной 10 см. с соединителем AMP

**LED**



**G4** - żarówka G4 20W/12V, komplet z kablem dł. 15 cm z wtykiem AMP  
- bulb G4 20W/12V, set includes 15 cm cable with AMP plug  
- Leuchtmittel G4 20W/12V, Komplet mit 15 cm Kabel und AMP Kontakt  
- лампочка G4 20Вт./12V, комплект с кабелем длиной 15 см. с соединителем AMP

**LED** - możliwe źródło światła LED G4 1.4W/12V DC, komplet z kablem dł. 2m z wtykiem  
- possibility of using the LED lamp G4 1.4W/12V DC, set includes 2m cable, with plug  
- möglichkeit des Anwenden die Leuchtmittel LED G4 1.4W/12V DC, Komplet mit 2m Kabel und Kontakt  
- возможный источник света LED лампочка G4 1,4Вт./12V DC, в комплекте с кабелем длиной 2м. с соединителем



**Oprawy podszafkowe z wyłącznikiem/ Under-cabinet luminaires with switch  
Unterbau-Leuchte mit Schalter/ Оправы под шкафчики с выключателем**

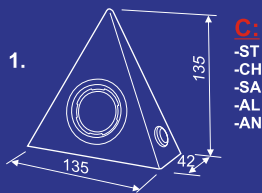

**C:**  
-ST  
-CH  
-SA  
-AL  
-AN

**trójkąt/ triangle/ Dreieck/  
треугольник**

U. Pat. RU 63938

NR	
TRW/...	G4 1x max 20W/12V
<b>LED TRWLED/...</b>	<b>LED 1,4W/12V DC</b>

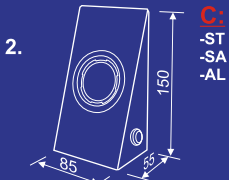

**C:**  
-ST  
-SA  
-AL

**klin/ wedge/ Keil/  
прямоугольник**

U. Pat. RU 63943

NR	
KLW/...	G4 1x max 20W/12V
<b>LED KLWLED/...</b>	<b>LED 1,4W/12V DC</b>

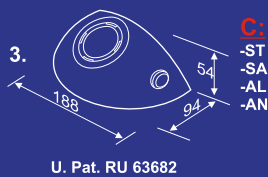

**C:**  
-ST  
-SA  
-AL  
-AN

**lezka/ tear/ Träne/  
полусфера**

U. Pat. RU 63682

NR	
LEW/...	G4 1x max 20W/12V
<b>LED LEWLED/...</b>	<b>LED 1,4W/12V DC</b>

**G4**

- żarówka G4 20W/12V, komplet z kablem dł. 15 cm z wtykiem AMP  
- bulb G4 20W/12V, set includes 15 cm cable with AMP plug  
- Leuchtmittel G4 20W/12V, Komplet mit 15 cm Kabel und AMP Kontakt  
- лампочка G4 20Вт./12V, комплект с кабелем длиной 15 см. с соединителем AMP

**LED**

- możliwe źródło światła LED G4 1,4W/12V DC, komplet z kablem dł. 2m z wtykiem  
- possibility of using the LED lamp G4 1.4W/12V DC, set includes 2m cable, with plug  
- möglichkeit des Anwenden die Leuchtmittel LED G4 1.4W/12V DC, Komplet mit 2m Kabel und Kontakt  
- возможный источник света LED лампочка G4 1,4Вт./12V DC, в комплекте с кабелем длиной 2м. с соединителем

szkło piaskowane sand-blasted Sandgestrahltes матовое стекло



**gniazdko w oprawie podszafkowej/ socket in under-cabinet holder / Steckdose in Unterbau-Rahmen  
розетка в светильнике**

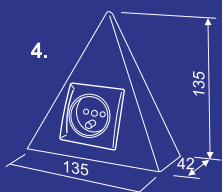

**C:**  
-ST  
-CH  
-SA  
-AL

NR	
GPTR/...	

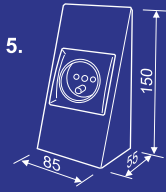

**C:**  
-ST

NR	
GPKL/...	

16A/250V IP20 CE

**wyłącznik w oprawie podszafkowej/ switch in under-cabinet holder/  
Schalter in Unterbau-Rahmen / выключатель в светильнике**

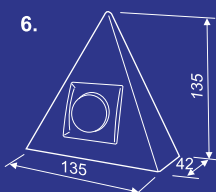

**C:**  
-ST  
-CH  
-SA  
-AL

NR	
WPTR/...	

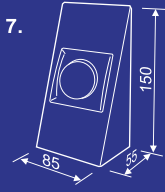

**C:**  
-ST

NR	
WPKL/...	

16A/250V IP20 CE

**C:** -kolory/ colours/ Farben/ цвета

CH	chrom/chrome/хром
AL	aluminium/алюминий
AN	antyk/antique/антик
SA	satyna/satin/nickel mat /сатин
ZL	złoto/gold/золото
ST	stal drapana/scratched steel/ Stahl gebuerstet/сталь

NR - nr kat. • cat.nr • Art.Nr • № в каталоге

- żarówka • bulb • Leuchtmittel • лампочка





NR	IL
(LED) ZTC1-65LED/...	1
(LED) ZTC2-65LED/...	2
(LED) ZTC3-65LED/...	3
(LED) ZTC4-65LED/...	4
(LED) ZTC5-65LED/...	5

NR	IL
ZTC1-65/...	1
ZTC2-65/...	2
ZTC3-65/...	3
ZTC4-65/...	4
ZTC5-65/...	5

C:  
-ST  
-CH  
-SA  
-AL  
-AN

-trójkąt z wyłącznikiem centralnym w zestawie  
-triangle set with central switch  
-Dreieck-Set mit Zentralschalter  
-треугольник с центральным выключателем в комплекте

**G4 LED**

ZTC 1,2,3 wyłącznik/switch/Schalter/выключатель BJB 6A  
ZTC 4,5 wyłącznik/switch/Schalter/выключатель BJB10A

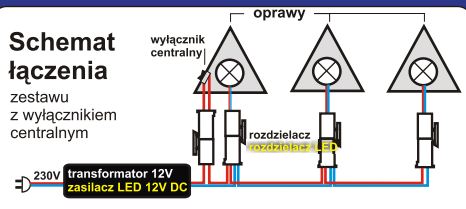

NR	IL
(LED) ZTW1-65LED/...	1
(LED) ZTW2-65LED/...	2
(LED) ZTW3-65LED/...	3
(LED) ZTW4-65LED/...	4
(LED) ZTW5-65LED/...	5

NR	IL
ZTW1-65/...	1
ZTW2-65/...	2
ZTW3-65/...	3
ZTW4-65/...	4
ZTW5-65/...	5

C:  
-ST  
-CH  
-SA  
-AL  
-AN

-trójkąt z wyłącznikiem przy każdej oprawie  
-triangle set with switches  
-Dreieck-Set mit Schalter  
-треугольник с выключателем в каждом светильнике

**G4 LED**

wyłącznik/switch/Schalter/выключатель BJB 6A

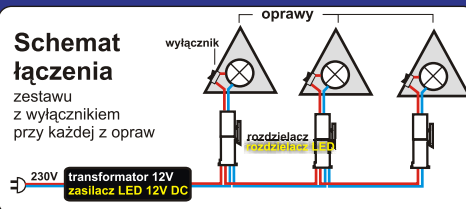

230V/50Hz

W skład zestawu wchodzi:

- oprawy wraz z żarówkami (od 1 do 5 szt.)
- transformator odpowiedni do potrzebnej mocy
- kabel zasilający z eurowtykiem długości 2m.
- rozdzielacz AMP.

Set includes:

- luminaires with bulbs (from 1 to 5 pcs)
- transformer adequate to used power
- feeder cable with Euro plug 2m
- AMP adapter

Packungsinhalt:

- Strahler mit Leuchtmittel ( 1 bis 5 Stck.)
- Trafo
- Anschlusskabel 2m lang
- AMP-Verteiler

В комплект входит:

- светильники с лампочками ( 1 - 5 шт.)
- трансформатор
- кабель с вилкой 2м.
- разделитель AMP

W skład zestawu LED wchodzi:

- (1- 5) x oprawa LED G4 1,4W/12V DC, LED w każdej z opraw
- Zasilacz napięcia stałego 12V/8W.
- Rozdzielacz
- Kabel sieciowy o długości 1,75m z wyłącznikiem.

Set includes:

- (1-5) x LED light G4 1,4W/12V DC, LED's in each light.
- adapter
- Electronic power supply 12V/8W.
- Feeder cable with switch 1,75m.

Inkl:

- (1-5) x LED Leuchten G4 1,4W/12V DC, pro Stück
- elektron. Trafo 12V/8W.
- Verteiler
- Eingang mit 1,75m. Zuleitung und Zwischenschalter

В комплект LED входит:

- (1-5 шт.) светильников LED G4 1,4Вт./12V DC, LED в каждом светильнике
- источник питания постоянного напряжения 12V/8Вт.
- разделитель
- сетевой кабель 1,75м. с выключателем



**G4**

- żarówki G4 10 lub 20W/12V system AMP
- bulbs G4 10 or 20W/12V, AMP system
- Leuchtmittel G4 10 oder 20W/12V, AMP Systeme
- лампочка G4 10 или 20Вт./12V, система AMP

**LED**

- możliwe źródło światła LED G4 1,4W/12V DC.
- possibility of using the LED lamp G4 1.4W/12V DC.
- möglichkeit des Anwenden die Leuchtmittel LED G4 1.4W/12V DC.
- возможный источник света LED лампочка G4 1,4Вт./12V DC

**NR**

- nr kat. • cat.nr • Art.Nr • № в каталогe

**IL**

- ilość • quantity • Menge • количество

C: -kolory/ colours/ Farben/ цвета

CH	chrom/chrome/chrom/хром
AL	aluminium/алюминий
AN	antyq/antique/antik/антик
SA	satyna/satin/nickel mat /сатин
ZL	zlot/gold/золото
ST	stal drapana/scratched steel/ Stahl gebuerstet/сталь



1. -klin z wyłącznikiem centralnym w zestawie  
-wedge set with central switch  
-Keil-Set mit Zentralschalter  
-прямоугольник с центральным выключателем в комплекте

NR	IL	NR	IL
ZKC1-65/...	1	LED ZKC1-65LED/...	1
ZKC2-65/...	2	LED ZKC2-65LED/...	2
ZKC3-65/...	3	LED ZKC3-65LED/...	3
ZKC4-65/...	4	LED ZKC4-65LED/...	4
ZKC5-65/...	5	LED ZKC5-65LED/...	5

**G4** **LED**  
ZKC 1,2,3 wyłącznik/switch/Schalter/выключатель BJB 6A  
ZKC 4,5 wyłącznik/switch/Schalter/выключатель BJB10A

2. -klin z wyłącznikiem przy każdej oprawie  
-wedge set with switches  
-Keil-Set mit Schalter  
-прямоугольник с выключателем в каждом светильнике

NR	IL	NR	IL
ZKW1-65/...	1	LED ZKW1-65LED/...	1
ZKW2-65/...	2	LED ZKW2-65LED/...	2
ZKW3-65/...	3	LED ZKW3-65LED/...	3
ZKW4-65/...	4	LED ZKW4-65LED/...	4
ZKW5-65/...	5	LED ZKW5-65LED/...	5

**G4** **LED**  
wyłącznik/switch/Schalter/выключатель BJB 6A

3. -lezka z wyłącznikiem centralnym w zestawie  
-tear set with central switch  
-Träne-Set mit Zentralschalter  
-полусфера с центральным выключателем в комплекте

NR	IL	NR	IL
ZLC1-65/...	1	LED ZLC1-65LED/...	1
ZLC2-65/...	2	LED ZLC2-65LED/...	2
ZLC3-65/...	3	LED ZLC3-65LED/...	3
ZLC4-65/...	4	LED ZLC4-65LED/...	4
ZLC5-65/...	5	LED ZLC5-65LED/...	5

**G4** **LED**  
ZLC 1,2,3 wyłącznik/switch/Schalter/выключатель BJB 6A  
ZLC 4,5 wyłącznik/switch/Schalter/выключатель BJB10A

4. -lezka z wyłącznikiem przy każdej oprawie  
-tear set with switches  
-Träne-Set mit Schalter  
-полусфера с выключателем в каждом светильнике

NR	IL	NR	IL
ZLW1-65/...	1	LED ZLW1-65LED/...	1
ZLW2-65/...	2	LED ZLW2-65LED/...	2
ZLW3-65/...	3	LED ZLW3-65LED/...	3
ZLW4-65/...	4	LED ZLW4-65LED/...	4
ZLW5-65/...	5	LED ZLW5-65LED/...	5

**G4** **LED**  
wyłącznik/switch/Schalter/выключатель BJB 6A

**Schemat łączenia**

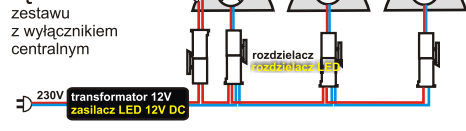

**Schemat łączenia**

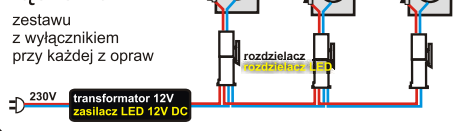

W skład zestawu wchodzi:  
- oprawy wraz z żarówkami (od 1 do 5 szt.)  
- transformator odpowiedni do potrzebnej mocy  
- kabel zasilający z eurowtykiem długości 2m.  
- rozdzielacz AMP.

Set includes:  
- luminaires with bulbs (from 1 to 5 pcs)  
- transformer adequate to used power  
- feeder cable with Euro plug 2m  
- AMP adapter

Packungsinhalt:  
- Strahler mit Leuchtmittel ( 1 bis 5 Stck.)  
- Trafo  
- Anschlusskabel 2m lang  
- AMP-Verteiler

В комплект входит:  
- светильники с лампочками ( 1 - 5 шт.)  
- трансформатор  
- кабель с вилкой 2м.  
- разделитель AMP

W skład zestawu LED wchodzi:  
- (1- 5) x oprawa LED G4 1,4W/12V DC, LED w każdej z opraw  
- Zasilacz napięcia stałego 12V/8W.  
- Rozdzielacz  
- Kabel sieciowy o długości 1,75m z wyłącznikiem.

Set includes:  
- (1-5) x LED light G4 1,4W/12V DC, LED's in each light.  
- adapter  
- Electronic power supply 12V/8W.  
- Feeder cable with switch 1,75m.

Inkl:  
- (1-5) x LED Leuchten G4 1,4W/12V DC, pro Stück  
- elektron. Trafo 12V/8W.  
- Verteiler  
- Eingang mit 1,75m. Zuleitung und Zwischenschalter

В комплект LED входит:  
- (1-5 шт.) светильников LED G4 1,4Вт./12V DC, LED в каждом светильнике  
- источник питания постоянного напряжения 12V/8W  
- разделитель  
- сетевой кабель 1,75м. с выключателем



**C:** -kolory/ colours/ Farben/ цвета

CH	chrom/chrome/chrom/хром
AL	aluminium /алюминий
AN	antyk/antique/antik /антик
SA	satyna/satin/nickel mat /сатин
ZL	złoto/gold/золото
ST	stal drapana/scratched steel/ Stahl gebuerstet/сталь

NR – nr kat. • cat.nr • Art.Nr • № в каталоге  
IL – ilość • quantity • Menge • количество



**G4** -żarówka G4 10 lub 20W/12V system AMP  
-bulbs G4 10 or 20W/12V, AMP system  
-Leuchtmittel G4 10 oder 20W/12V, AMP Systeme  
-лампочка G4 10 или 20Вт./12V, система AMP.

**LED** -możliwe źródło światła LED G4 1,4W/12V DC, possibility of using the LED lamp G4 1.4W/12V DC, möglichkeit des Anwenden die Leuchtmittel LED G4 1.4W/12V DC, -возможный источник света LED лампочка G4 1,4Вт./12V DC

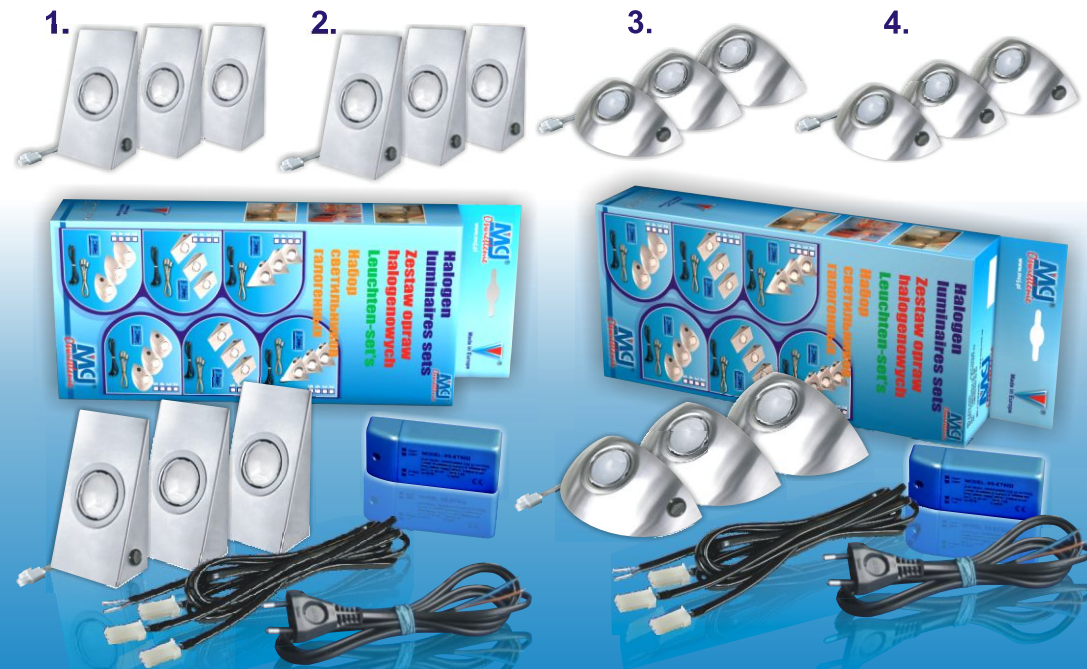

1. 2.

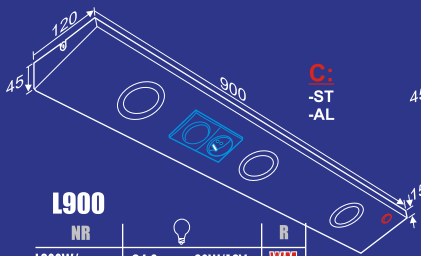

C:  
-ST  
-AL

**L900**

NR	Light	R
L900W/...	G4 3x max 20W/12V	WWM
L900GW/...	G4 3x max 20W/12V	GW
LED L900WLED/...	LED 3x 1,4W/12V DC	WWM
LED L900GWLED/...	LED 3x 1,4W/12V DC	GW

3. 4.

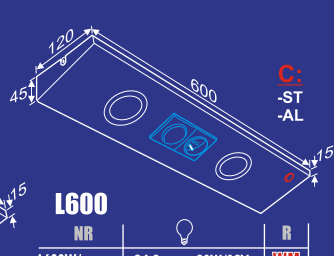

C:  
-ST  
-AL

**L600**

NR	Light	R
L600W/...	G4 2x max 20W/12V	WWM
L600GW/...	G4 2x max 20W/12V	GW
LED L600WLED/...	LED 2x 1,4W/12V DC	WWM
LED L600GWLED/...	LED 2x 1,4W/12V DC	GW

5. 6.

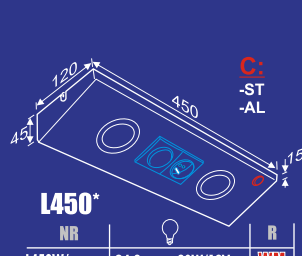

C:  
-ST  
-AL

**L450\***

NR	Light	R
L450W/...	G4 2x max 20W/12V	WWM
L450GW/...	G4 2x max 20W/12V	GW
LED L450WLED/...	LED 2x 1,4W/12V DC	WWM
LED L450GWLED/...	LED 2x 1,4W/12V DC	GW

7. 8.

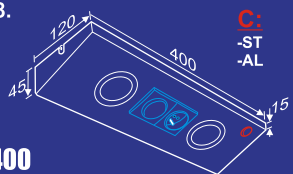

C:  
-ST  
-AL

**L400**

NR	Light	R
L400W/...	G4 2x max 20W/12V	WWM
L400GW/...	G4 2x max 20W/12V	GW
LED L400WLED/...	LED 2x 1,4W/12V DC	WWM
LED L400GWLED/...	LED 2x 1,4W/12V DC	GW

9. 10.

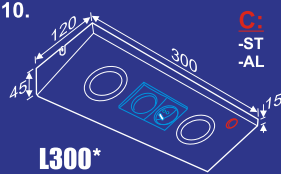

C:  
-ST  
-AL

**L300\***

NR	Light	R
L300W/...	G4 2x max 20W/12V	WWM
L300GW/...	G4 2x max 20W/12V	GW
LED L300WLED/...	LED 2x 1,4W/12V DC	WWM
LED L300GWLED/...	LED 2x 1,4W/12V DC	GW

C: -kolory/ colours/ Farben/ цвета

ST-stal drapanana/scratched steel/  
Stahl gebuerstet/сталь  
AL-aluminium /алюминий



R - rodzaj • sort • Art  
NR - nr kat. • cat.nr • Art.Nr • № в каталоге  
Light bulb icon - żarówka • bulb • Leuchtmittel • лампочка

WWM - z wyłącznikiem meblowym 10(4)A/250V • with furniture switch 10(4)A/250V • mit Moebel Schalter 10(4)A/250V  
с мебельным выключателем 10(4)A/250V  
GW - z gniazdkiem i wyłącznikiem 16A/250V • with socket and switch 16A/250V • mit Schalter und Steckdose 16A/250V  
с розеткой и выключателем 16A/250V

komplet z transformatorem i kablem dl.2m • complet includes transformer and 2m cable • mit Elektronisches Trafo, Anschlusskabel 2m Laenge  
комплект с трансформатором и кабелем

**LED** - możliwe źródło światła LED G4 1,4W/12V DC.  
- possibility of using the LED lamp G4 1,4W/12V DC.  
- möglichkeit des Anwenden die Leuchtmittel LED G4 1,4W/12V DC.  
- возможный источник света LED лампочка G4 1,4Вт./12V DC

\* - Na specjalne zamówienie - Termin realizacji do 21 dni • For special order - realization term up to 21days  
Fuer speziell Bestellung - Termin realisierung zum 21 Tage • по специальному заказу - срок исполнения до 21 дня.

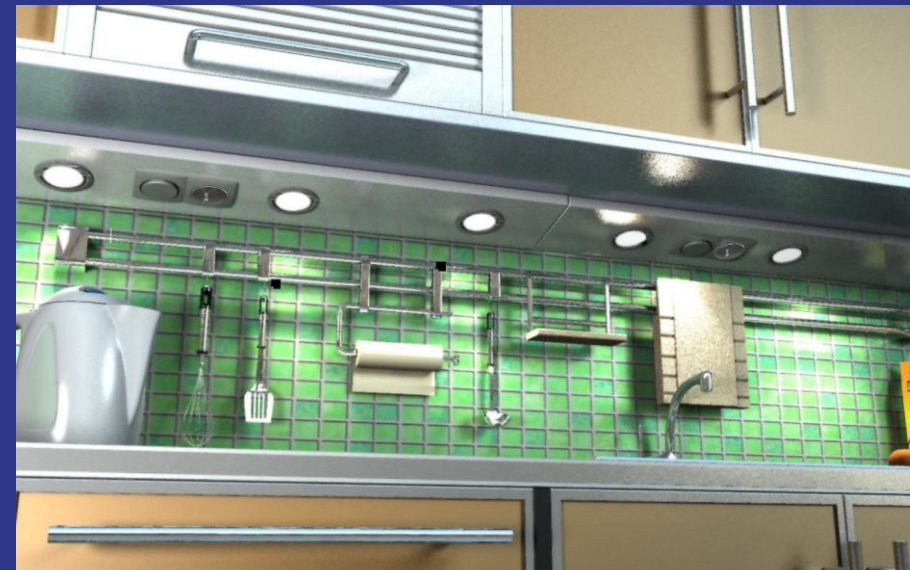



**MST5** oprawa świetłówkowa/ fluorescent luminaire/  
Leuchtstofflampe/ корпус люминесцентной лампы

NR	DL	Light Bulb
MST5/6	265 mm	6W
MST5/8	345 mm	8W
MST5/13	575 mm	13W
MST5/21	906 mm	21W
MST5/28	1206 mm	28W

świetłówa T5/G5, komplet z kablem dl. 1,8m  
fluorescent lamp T5/G5, set includes 1,8m cable  
Leuchtstoffrohren T5/G5, Komplett mit 1,8m Kabel.  
люминесцентная лампа T5/G5, комплект  
с кабелем длиной 1,8 м.



230V/50Hz

**P.../MST5**

przedłużacz  
extension cable  
Verlängerung  
удлинитель

NR	DL
P15/MST5	15 cm
P30/MST5	30 cm
P50/MST5	50 cm



230V/50Hz

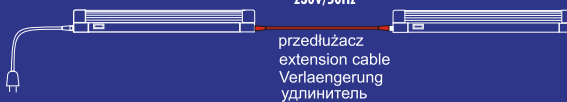

przedłużacz  
extension cable  
Verlängerung  
удлинитель



**MST4** oprawa świetłówkowa/ fluorescent luminaire/  
Leuchtstofflampe/ корпус люминесцентной лампы

świetłówa T4/G4, komplet z kablem dl. 1,8m  
fluorescent lamp T4/G4, set includes 1,8m cable  
Leuchtstoffrohren T4/G4, Komplett mit 1,8m Kabel  
люминесцентная лампа T4/G4, комплект  
с кабелем длиной 1,8 м.

NR	DL	Light Bulb
MST4/6	274 mm	6W
MST4/8	394 mm	8W
MST4/16	524 mm	16W
MST4/20	624 mm	20W
MST4/30	815 mm	30W



-BI



230V/50Hz

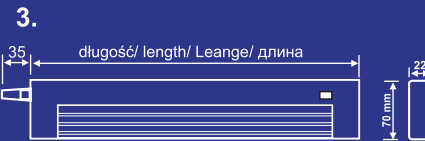

**MSPW** oprawa świetłówkowa  
fluorescent luminaire  
Leuchtstofflampe  
корпус люминесцентной лампы

NR	DL	Light Bulb
MSPW/T5/8/...	340 mm	8W
MSPW/T5/13/...	553 mm	13W



230V/50Hz

świetłówa T5/G5, komplet z kablem dl. 1,8m  
fluorescent lamp T5/G5, set includes 1,8m cable  
Leuchtstoffrohren T5/G5, Komplett mit 1,8m Kabel.  
люминесцентная лампа T5/G5, комплект  
с кабелем длиной 1,8 м.

**NR** - nr kat. • cat.nr • Art.Nr • № в каталоге

**DL** - długość • length • Leange • длина

Light Bulb - żarówka • bulb • Leuchtmittel • лампочка



-AL



230V/50Hz

**MSRS**

NR	DL	Light Bulb
MSRS/T5/8	350 mm	8W
MSRS/T5/13	580 mm	13W
MSRS/T5/21	912 mm	21W
MSRS/T5/28	1212 mm	28W

świetłówa T5/G5, komplet z kablem dl. 1,5m i złączką  
fluorescent lamp T5/G5, set includes 1,5m cable  
Leuchtstoffrohren T5/G5, Komplett mit 1,5m Kabel.  
люминесцентная лампа T5/G5, комплект  
с кабелем длиной 1,5 м. и соединителем

**C** -kolory/ colours/ Farben/ цвета

**BI**-biały/white/weiss/белый

**AL**-aluminium/алюминий

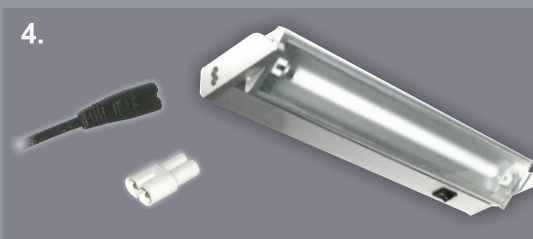
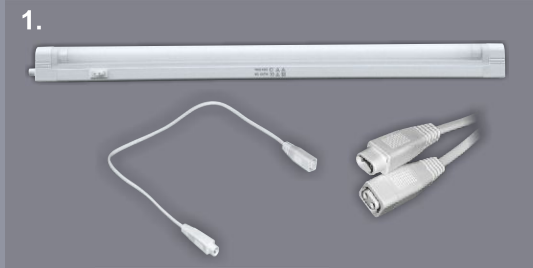

**OSLW**

NR	DL	💡
OSLW 364/...	364mm	1x LC6/12V DC
OSLW 414/...	414mm	1x LC6/12V DC
OSLW 564/...	564mm	1x LC9/12V DC
OSLW 764/...	764mm	2x LC6/12V DC
OSLW 864/...	864mm	2x LC6/12V DC
OSLW 1164/...	1164mm	2x LC9/12V DC

U.Pat

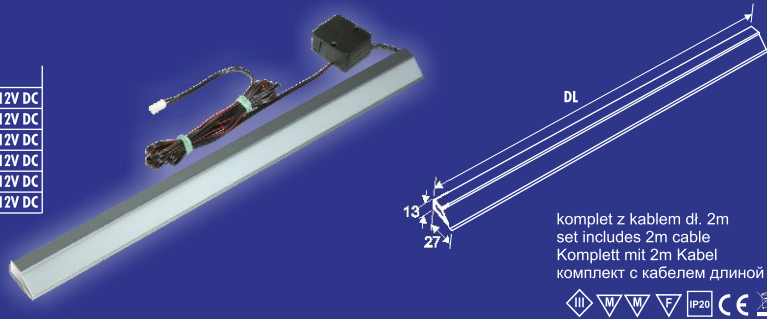

komplet z kablem dł. 2m  
set includes 2m cable  
Komplett mit 2m Kabel  
комплект с кабелем длиной 2м.



**OSLW/B**

NR	DL	💡
OSLW 364/B/...	364mm	1x LC6/12V DC
OSLW 414/B/...	414mm	1x LC6/12V DC
OSLW 564/B/...	564mm	1x LC9/12V DC
OSLW 764/B/...	764mm	2x LC6/12V DC
OSLW 864/B/...	864mm	2x LC6/12V DC
OSLW 1164/B/...	1164mm	2x LC9/12V DC

U.Pat

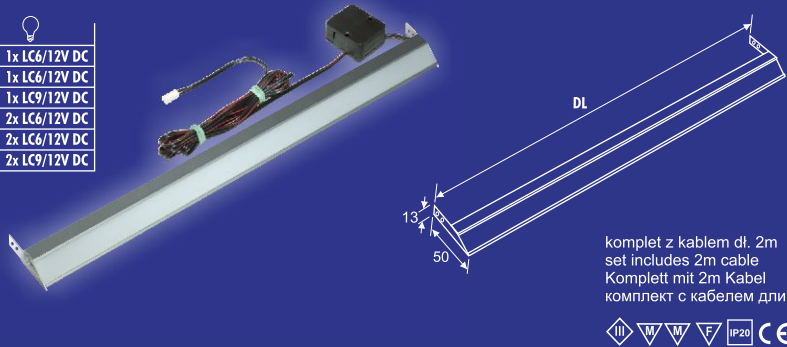

komplet z kablem dł. 2m  
set includes 2m cable  
Komplett mit 2m Kabel  
комплект с кабелем длиной 2м.



kolory/ colour/ Farben / цвета

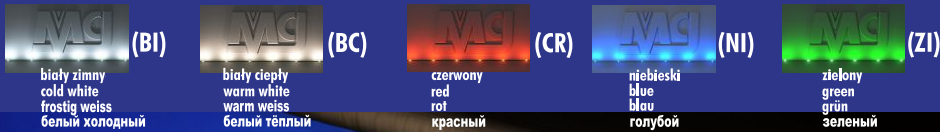

**OSS**

NR	DL	💡
OSS 364/...	364mm	2x LC3/12V DC
OSS 414/...	414mm	1x LC6/12V DC
OSS 564/...	564mm	1x LC9/12V DC
OSS 764/...	764mm	2x LC6/12V DC
OSS 864/...	864mm	2x LC6/12V DC
OSS 1164/...	1164mm	2x LC9/12V DC



komplet z kablem dł. 2m  
set includes 2m cable  
Komplett mit 2m Kabel  
комплект с кабелем длиной 2м.



kolory/ colour/ Farben / цвета

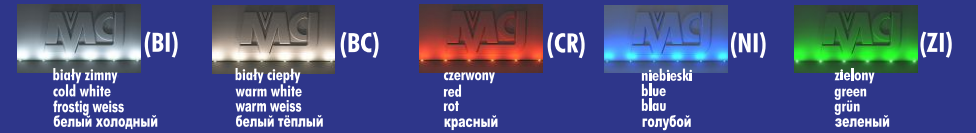

💡 - żarówka • bulb • Leuchtmittel • лампочка DL - długość • length • Leange • длина NR - nr kat. • cat.nr • Art.Nr • № в каталоге

💡 - żarówka • bulb • Leuchtmittel • лампочка DL - długość • length • Leange • длина NR - nr kat. • cat.nr • Art.Nr • № в каталоге



**Nakładki ledowe do półek szklanych**  
**LED overlaps for glass shelves**  
**LED Glassregalleuchte**  
**Накладки LED для стеклянных полок**

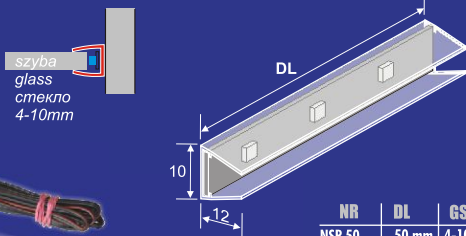

NR	DL	GS	💡
NSP 50	50 mm	4-10 mm	LC3/45/12V DC
NSP 100	100 mm	4-10 mm	LC3/12V DC
NSP 150	150 mm	4-10 mm	LC3/12V DC
NSP 360	360 mm	4-10 mm	LC6/12V DC
NSP 560	560 mm	4-10 mm	LC9/12V DC

komplet z kablem dł. 2m  
 set includes 2m cable  
 Komplet mit 2m Kabel  
 комплект с кабелем длиной 2м.



U. Pat. W117738

**Nakładki ledowe do półek szklanych**  
**LED overlaps for glass shelves**  
**LED Glassregalleuchte**  
**Накладки LED для стеклянных полок**

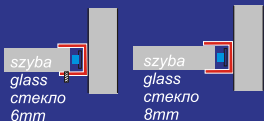

NR	DL	GS	💡
NS8 50	50 mm	8 mm	LC3/45/12V DC
NS8 100	100 mm	8 mm	LC3/12V DC
NS8 150	150 mm	8 mm	LC3/12V DC
NS8 360	360 mm	8 mm	LC6/12V DC
NS8 560	560 mm	8 mm	LC9/12V DC
NS8/15/360	360 mm	8 mm	LC15/12V DC
NS8/15/560	560 mm	8 mm	LC15/12V DC

NR	DL	GS	💡
NS6 50	50 mm	6 mm	LC3/45/12V DC
NS6 100	100 mm	6 mm	LC3/12V DC
NS6 150	150 mm	6 mm	LC3/12V DC
NS6 360	360 mm	6 mm	LC6/12V DC
NS6 560	560 mm	6 mm	LC9/12V DC
NS6/15/360	360 mm	6 mm	LC15/12V DC
NS6/15/560	560 mm	6 mm	LC15/12V DC

komplet z kablem dł. 2m  
 set includes 2m cable  
 Komplet mit 2m Kabel  
 комплект с кабелем длиной 2м.



**przedłużacz LED**  
**LED extension cable**  
**LED Verlaengerung**  
**удлинитель LED**

NR	DL
PZ/LED/100	100cm
PZ/LED/200	200cm

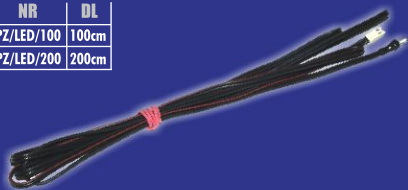

zasilacz 12V/8W  
 electronic power supply 12V/8W  
 elektron. Trafo 12V/8W  
 источник питания 12V/8W

Przykładowe listwy LED instalowane w nakładkach - nie sprzedawane osobno  
 LED modules installed in LED overlaps - not for sale  
 Leiste LED für LED Glassregalleuchten. Nich einzeln verkauft  
 Образцы планок LED установленные в накладках - не продаются отдельно

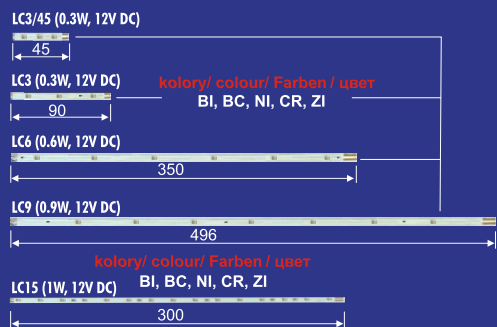

**Nakładki ledowe do półek z płyty**  
**LED overlaps for wooden shelves**  
**LED Regalleuchte**  
**Накладки LED к полкам из ДСП**

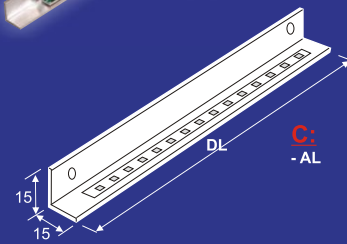
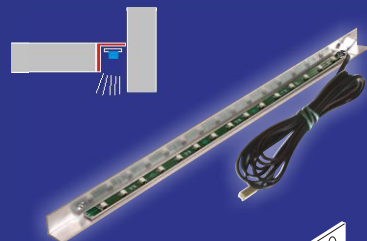

NR	DL	💡
NP 50	50 mm	LC3/45/12V DC
NP 100	100 mm	LC3/12V DC
NP 150	150 mm	LC3/12V DC
NP 360	360 mm	LC6/12V DC
NP 560	560 mm	LC9/12V DC
NP/15/360	360 mm	LC15/12V DC
NP/15/560	560 mm	LC15/12V DC

komplet z kablem dł. 2m  
 set includes 2m cable  
 Komplet mit 2m Kabel  
 комплект с кабелем длиной 2м.



**Luna-AS**

do podświetlania półek szklanych  
 to illuminate glass shelves  
 Glasregal-Leuchte  
 для подсветки стеклянных полок

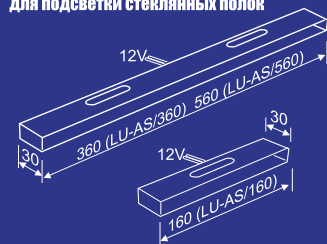

NR	DL	💡
LU-AS/160	160 mm	G4 1x max 20W/12V
LU-AS/360	360 mm	G4 2x max 20W/12V
LU-AS/560	560 mm	G4 2x max 20W/12V

- kabel dł. 30cm z wtykiem AMP  
 - set includes 30 cm cable with AMP plug  
 - 30cm Kabel und AMP Kontakt  
 - с кабелем длиной 30 см. с соединителем AMP



kolory/ colour/ Farben / цвета

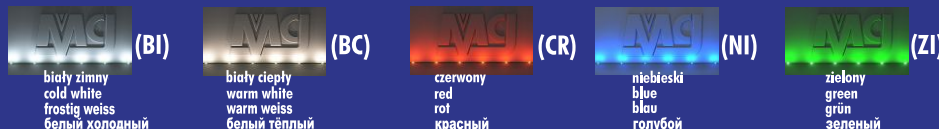

**DL** - długość • length • Leange • длина  
**NR** - nr kat. • cat.nr • Art.Nr • № в каталоге

💡 - żarówka • bulb • Leuchtmittel • лампочка  
**GS** - grubość szyby • glass thickness • Glasdicke  
 толщина стекла

**C:** -kolory/ colours/ Farben/ цвет  
**AL**-aluminium/алюминий

Listwy LED/ Led module/ Led Leiste/ панель LED

NR	LIL 6/12,5...	LIL 9/18,5...	LIL 15/30...
DL	125 mm	185 mm	300 mm
	LIL 6	LIL 9	LIL 15
	0,4W/12V DC	0,6W/12V DC	1W/12V DC

komplet z kablem dł. 2m  
set includes 2m cable  
Komplett mit 2m Kabel  
комплект с кабелем длиной 2м.

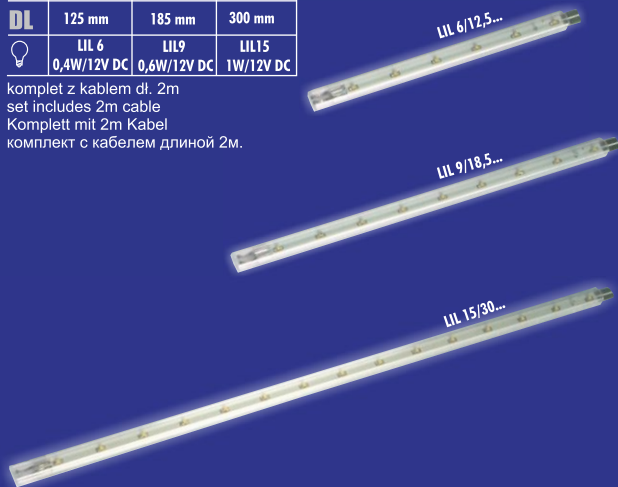

LED  
kolory/ colour/ Farben / цвета

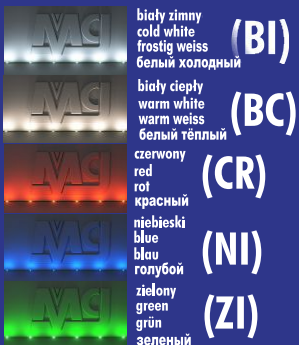

Oświetlenie listwowe LED - LED module  
LED Leiste - Светильники LED

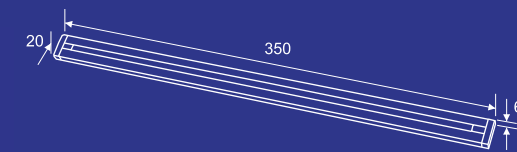
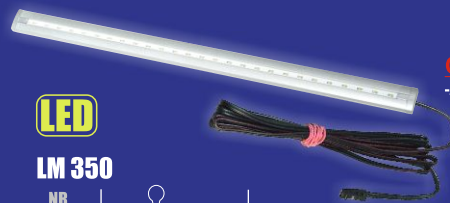

LM 350

NR	
LM 350	LED 2,2W/12V DC

LED: BI  
komplet z kablem dł. 2m  
set includes 2m cable  
Komplett mit 2m Kabel  
комплект с кабелем длина 2м.



LED

zasilacz 8W/12V  
electronic power supply 8W/12V  
elektron. Trafo 8W/12V  
источник питания 8Вт./12V

NR	W min-max
Z-LED/8W	0-8

zasilacz 12V DC/8W wraz z kablem zasilającym dł. 1,75m i wyłącznikiem przelotowym  
electronic power supply 12V DC/8W with feeder cable 1,75m, passage switch  
elektron. Trafo 12V DC/8W, Anschluss-kabel 1,75m mit Schalter  
источник питания вместе с кабелем длиной 1,75м. и выключателем «бра»

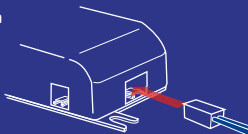
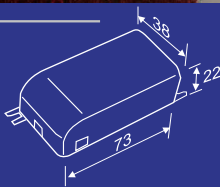

Rozdzielacz LED - LED adapter - LED Verteiler - разделитель LED

NR	IL
R-LED/5	5

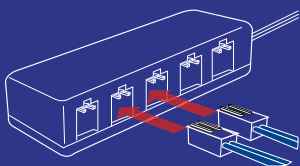

Łącznik LED - LED connector - соединитель LED

NR	DL
LL/5	5cm
LL/30	30cm
LL/50	50cm



zasilacz 12V/8W  
electronic power supply 12V/8W  
elektron. Trafo 12V/8W  
источник питания 12V/8W

łącznik  
connector  
соединитель

NR - nr kat. • cat.nr • Art.Nr • № в каталоге  
DL - długość • length • Leange • длина  
IL - ilość • quantity • Menge • количество

OSL

NR	DL	
OSL 364/...	364mm	1x LC6/12V DC
OSL 414/...	414mm	1x LC6/12V DC
OSL 564/...	564mm	1x LC9/12V DC
OSL 764/...	764mm	2x LC6/12V DC
OSL 864/...	864mm	2x LC6/12V DC
OSL 1164/...	1164mm	2x LC9/12V DC

U. Pat.

OSL/B

NR	DL	
OSL 364/B/...	364mm	1x LC6/12V DC
OSL 414/B/...	414mm	1x LC6/12V DC
OSL 564/B/...	564mm	1x LC9/12V DC
OSL 764/B/...	764mm	2x LC6/12V DC
OSL 864/B/...	864mm	2x LC6/12V DC
OSL 1164/B/...	1164mm	2x LC9/12V DC

U. Pat.

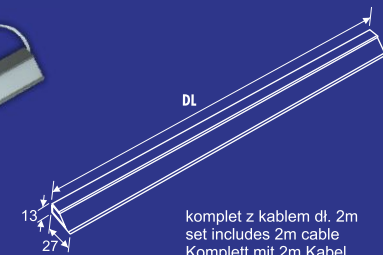
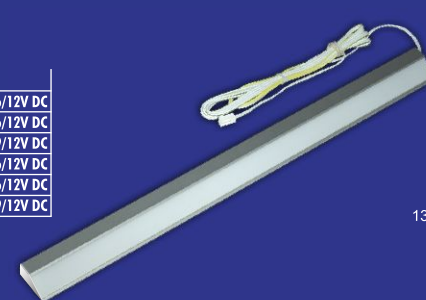

komplet z kablem dł. 2m  
set includes 2m cable  
Komplett mit 2m Kabel  
комплект с кабелем длиной 2м.

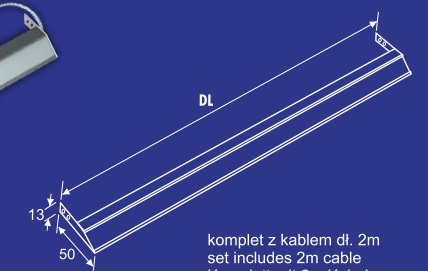
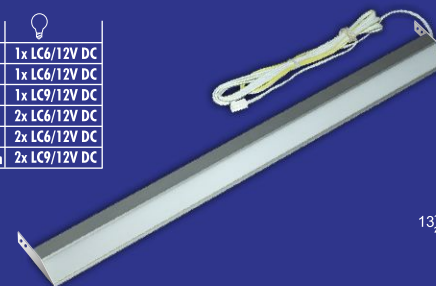

komplet z kablem dł. 2m  
set includes 2m cable  
Komplett mit 2m Kabel  
комплект с кабелем длиной 2м.



kolory/ colour/ Farben / цвета

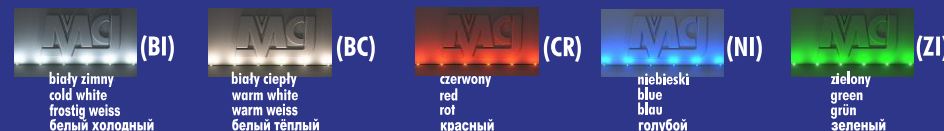



U. Pat. W117929



### SLP/P

NR	DL	💡
SLP 230/P/.../...	230mm	2xLC3/12V DC
SLP 320/P/.../...	320mm	3xLC3/12V DC
SLP 400/P/.../...	400mm	1xLC6/12V DC
SLP 520/P/.../...	520mm	1xLC9/12V DC

... -W (wyłącznik/ switch/ schalter/ выключатель)  
... -kolor LED/ LED colour/ LED farben/ цвет LED



### SLP/D

NR	DL	💡
SLP 230/D/.../...	230mm	2xLC3/12V DC
SLP 320/D/.../...	320mm	3xLC3/12V DC
SLP 400/D/.../...	400mm	1xLC6/12V DC
SLP 520/D/.../...	520mm	1xLC9/12V DC

... -W (wyłącznik/ switch/ schalter/ выключатель)  
... -kolor LED/ LED colour/ LED farben/ цвет LED



### SLP/G

NR	DL	💡
SLP 230/G/.../...	230mm	2xLC3/12V DC
SLP 320/G/.../...	320mm	3xLC3/12V DC
SLP 400/G/.../...	400mm	1xLC6/12V DC
SLP 520/G/.../...	520mm	1xLC9/12V DC

... -W (wyłącznik/ switch/ schalter/ выключатель)  
... -kolor LED/ LED colour/ LED farben/ цвет LED



łącznik  
connector  
соединитель

### SLP/L

komplet z kablem dł. 2m  
set includes 2m cable  
Komplett mit 2m Kabel  
комплект с кабелем длиной 2м.



kolory/ colour/ Farben / цвета

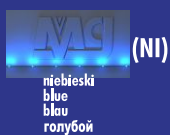
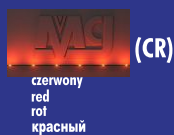

## Oprawa LED z wyłącznikiem zbliżeniowym LED luminaire with Close Switch LED Leuchten mit Annäherungsschalter Светильник LED с выключателем фотоэлементом



U. Pat

C:  
-AL

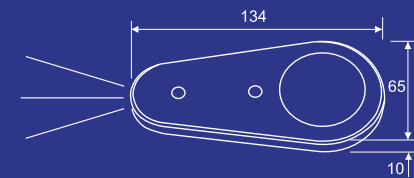

**LED**

**OLW**

NR	💡
OLW	1W/12V DC

LED: BC

komplet z kablem dł. 2m  
set includes 2m cable  
Komplett mit 2m Kabel  
комплект с кабелем длиной 2м.



C: -kolory/ colours/ Farben/ цвет  
AL-aluminium /алюминий

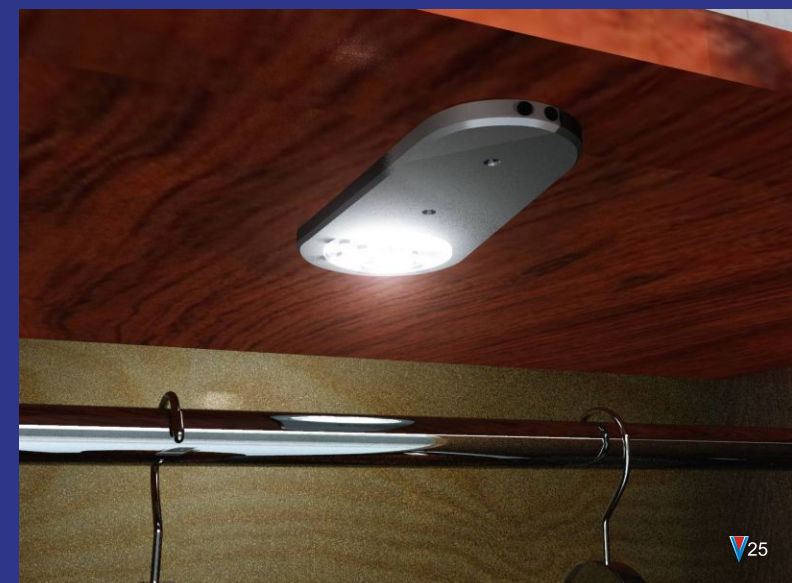



**Tukan GW**

NR	LED 1W/4V DC	R
GWL	LED 1W/4V DC	P
GWP	LED 1W/4V DC	L

LED: BC



U.Pat

C: -AL

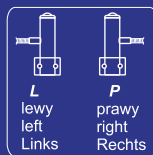
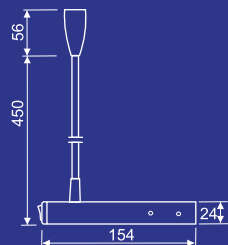

komplet z kablem 2,5m i zasilaczem wtyczkowym LED  
set includes 2,5m cable, with electronic power supply  
Komplett mit 2,5m Kabel und elektron. Trafo  
комплект с кабелем длиной 2,5м. штепсельный источник питания LED



**MINI**

NR	G4 1x max 10W/12V
----	-------------------

komplet z kablem 2m, system AMP  
set includes 2m cable, AMP system  
Komplett mit 2m Kabel, AMP systeme  
комплект с кабелем длиной 2м. Система AMP



C: -AL

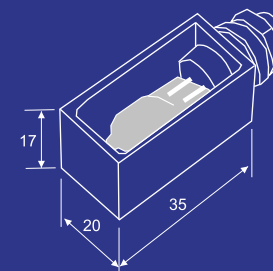

**Tukan SL**

NR	LED 1W/4V DC
SL	LED 1W/4V DC

LED: BC



C: -AL

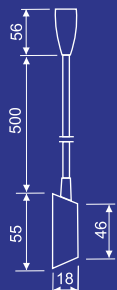

komplet z kablem 2,5m i zasilaczem wtyczkowym LED  
set includes 2,5m cable, with electronic power supply  
Komplett mit 2,5m Kabel und elektron. Trafo  
комплект с кабелем длиной 2,5м. штепсельный источник питания LED

**zasilacz wtyczkowy LED 1W/4V**

NR	(W) min-max
ZW-TL LED	0-1

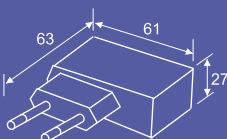

-zasilacz wtyczkowy 1W/4V DC 350mA, łącznie z kablem o dł. 1,5m.  
-AC/DC Wall Plug adapter 1W/4V DC 350mA, with feeder cable 1,5m.  
-AC/DC Adapter 1W/4V DC 350mA, Anschluss-kabel 1,5m.  
-штепсельный источник питания 1Вт./4V DC 350mA, с кабелем длиной 1,5м.

R - rodzaj • type • Type • род  
P - prawy • right • Rechts • правый  
L - lewy • left • Links • левый

C: -kolory/ colours/ Farben/ цвета  
AL-aluminium/ алюминий

★ - towar na zamówienie - for order - fuer Bestellung - товар по заказу



C: -kolory/ colours/ Farben/ цвета  
AL-aluminium/ алюминий

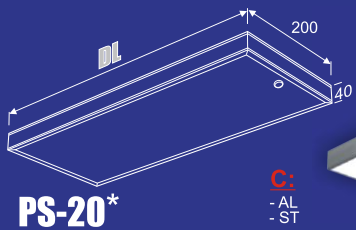

**PS-20\***

C:  
- AL  
- ST

NR	S	DL	💡	KG
PS-20/400/...	200 mm	400 mm	1xT5 6W	3,0 kg
PS-20/600/...	200 mm	600 mm	1xT5 8W	3,0 kg
PS-20/700/...	200 mm	700 mm	1xT5 13W	3,0 kg
PS-20/900/...	200 mm	900 mm	1xT5 13W	3,0 kg

⊕ ⏚ ⏚ ⏚ ⏚ IP20 CE 230V/50Hz

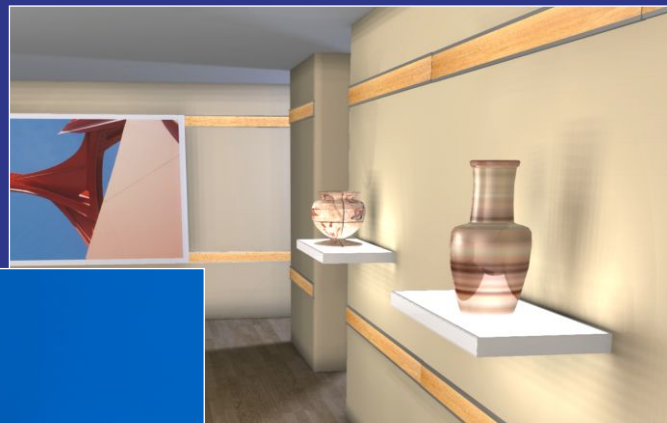
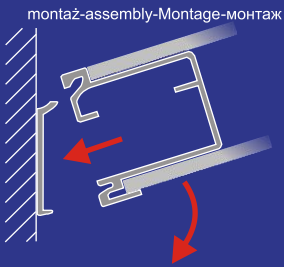

**Półka szklana LED - LED glass shelves**  
**LED glass shelves - Стекланная полка LED**

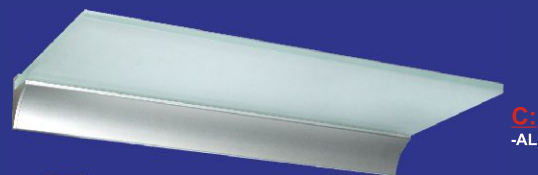

**LED PLED\***

C:  
- AL

NR	DL	💡	KG	GS
P 400 LED/...	400 mm	1C6/12V DC	2,0 kg	8 mm
P 600 LED/...	600 mm	1C9/12V DC	2,0 kg	8 mm
P 900 LED/...	900 mm	2x1C6/12V DC	2,0 kg	8 mm

komplet z kablem dł. 2m  
set includes 2m cable  
Komplett mit 2m Kabel  
комплект с кабелем длиной 2м.

⊕ ⏚ ⏚ ⏚ ⏚ IP20 CE 230V/50Hz

**Spody do szafek kuchennych Bottoms of kitchen units**  
**Кухенрегал**  
**Светящаяся нижняя полка для для кухонных шкафчиков**



**DS-28\***

C:  
- AL  
- ST

NR	S	DL	💡
DS-28/414/...	282 mm	414 mm	1xT5 6W
DS-28/564/...	282 mm	564 mm	1xT5 8W
DS-28/764/...	282 mm	764 mm	1xT5 13W
DS-28/864/...	282 mm	864 mm	1xT5 13W

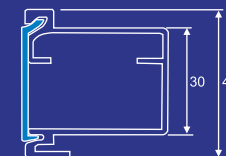

montaż-assembly-Montage-монтаж

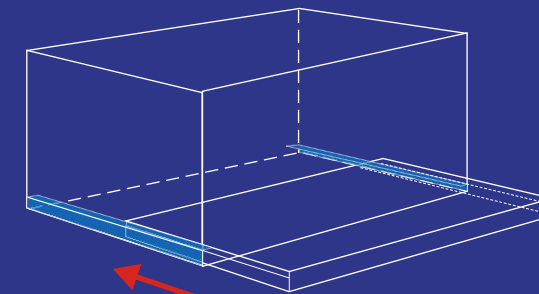

⊕ ⏚ ⏚ ⏚ ⏚ IP20 CE 230V/50Hz

**LED**  
**kolory/ colour/ Farben/ цвета**

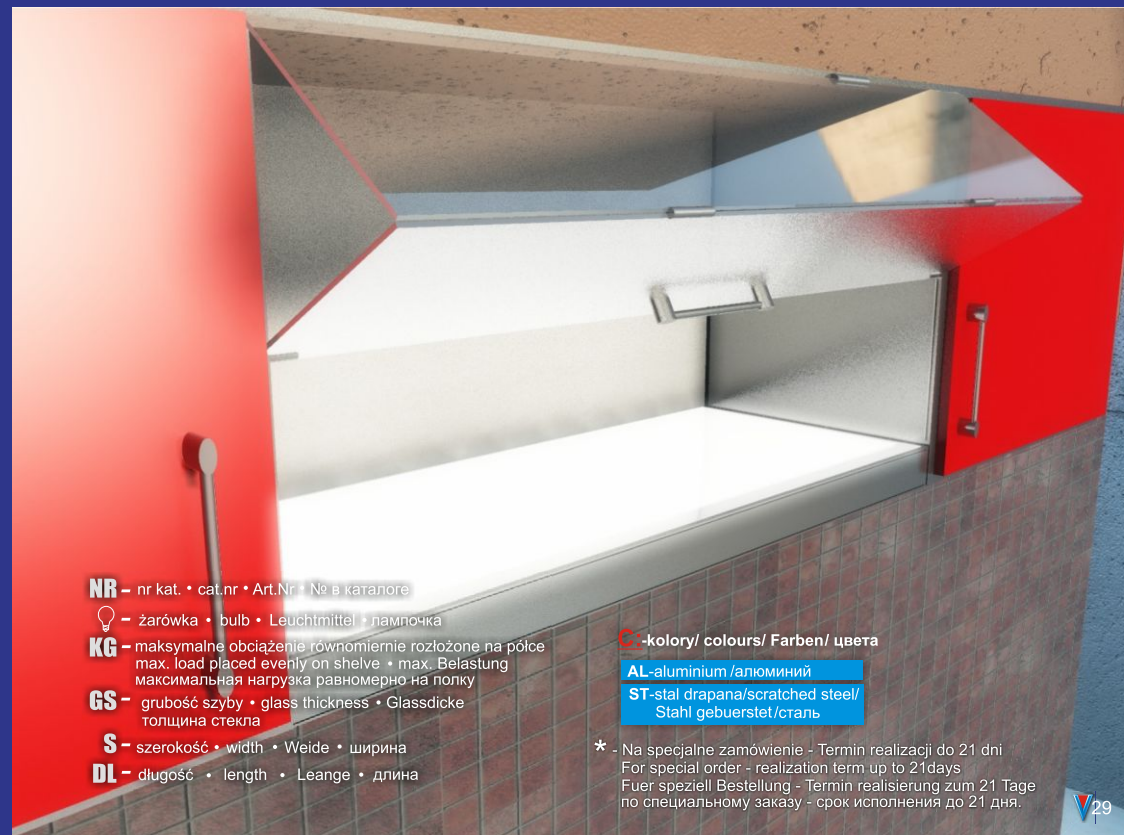

**NR** - nr kat. • cat.nr • Art.Nr • № в каталоге

💡 - żarówka • bulb • Leuchtmittel • лампочка

**KG** - maksymalne obciążenie równomiernie rozłożone na półce  
max. load placed evenly on shelf • max. Belastung  
максимальная нагрузка равномерно на полку

**GS** - grubość szczyby • glass thickness • Glassdicke  
толщина стекла

**S** - szerokość • width • Weide • ширина

**DL** - długość • length • Leange • длина

C-**kolory/ colours/ Farben/ цвета**

**AL**-aluminium /алюминий

**ST**-stal drapaną/scratched steel/  
Stahl gebuerstet/сталь

\* - Na specjalne zamówienie - Termin realizacji do 21 dni  
For special order - realization term up to 21days  
Für speziell Bestellung - Termin realisierung zum 21 Tage  
по специальному заказу - срок исполнения до 21 дня.



C:  
-AL  
-CH

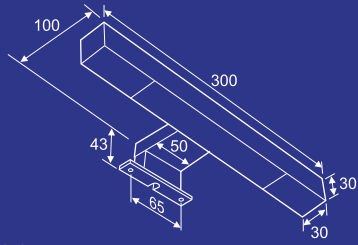

U. Pat. W 117601

**Karo 300**

NR	
KR300/...	R7S 1x max 60W/230V



C:  
-AL  
-CH

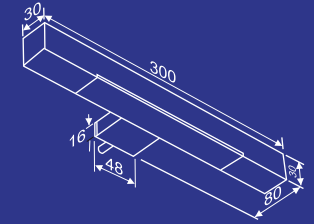

U. Pat. W 117696

★  
**Karo 300D**

NR	
KR300D/...	R7S 1x max 60W/230V



C:  
-AL  
-CH

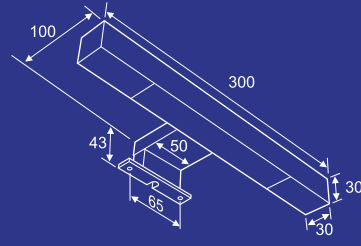

U. Pat. W 117601

**LED**

**Karo 300LED**

NR	
KR300LED/...	LED30 1x 5W/230V
LED: BI	



C:  
-AL  
-CH

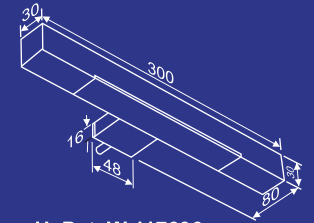

U. Pat. W 117696

★  
**LED**

**Karo 300DLED**

NR	
KR300DLED/...	LED30 1x 5W/230V
LED: BI	



NR – nr kat. • cat.nr • Art.Nr • № в каталоге

– żarówka • bulb • Leuchtmittel • лампочка

★ - towar na zamówienie - for order - Fuer Bestellung - товар по заказу

C: -kolory/ colours/ Farben/ цвета

AL-aluminium /алюминий

CH-chrom/chrome/chrom/хром



★  
**Karo 300N**

NR	
KR300N/...	R7S 1x max 60W/230V

U. Pat. W 117697



C:  
-AL  
-CH

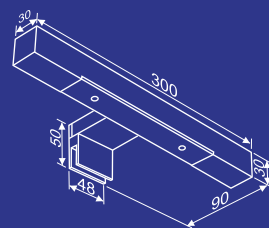

★  
**LED**

**Karo 300NLED**

NR	
KR300NLED/...	LED30 1x 5W/230V

LED: BI  
U. Pat. W 117697



C:  
-AL  
-CH

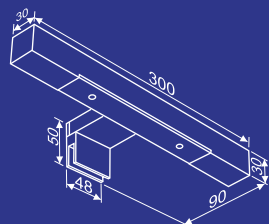

**Karo 590**

NR	
KR590/...	R7S 2x max 60W/230V



U. Pat. W 117601

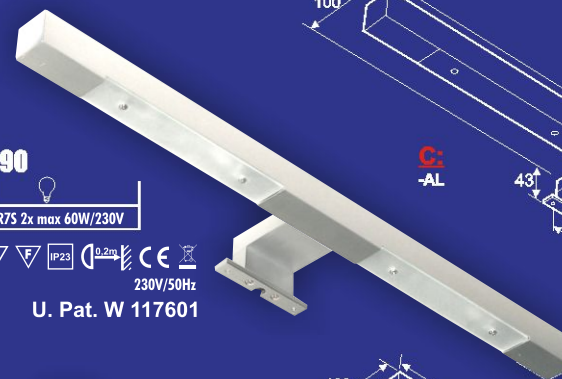

C:  
-AL

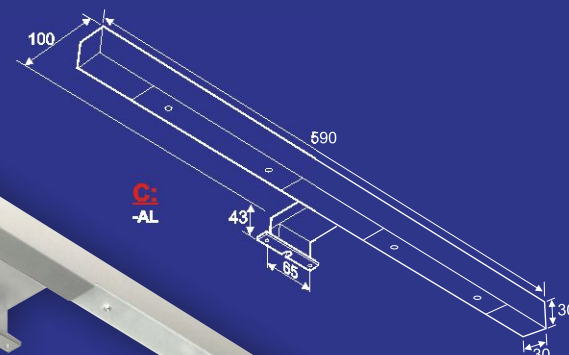

**LED**

**Karo 590LED**

NR	
KR590LED/...	LED30 2x 5W/230V



U. Pat. W 117601



C:  
-AL

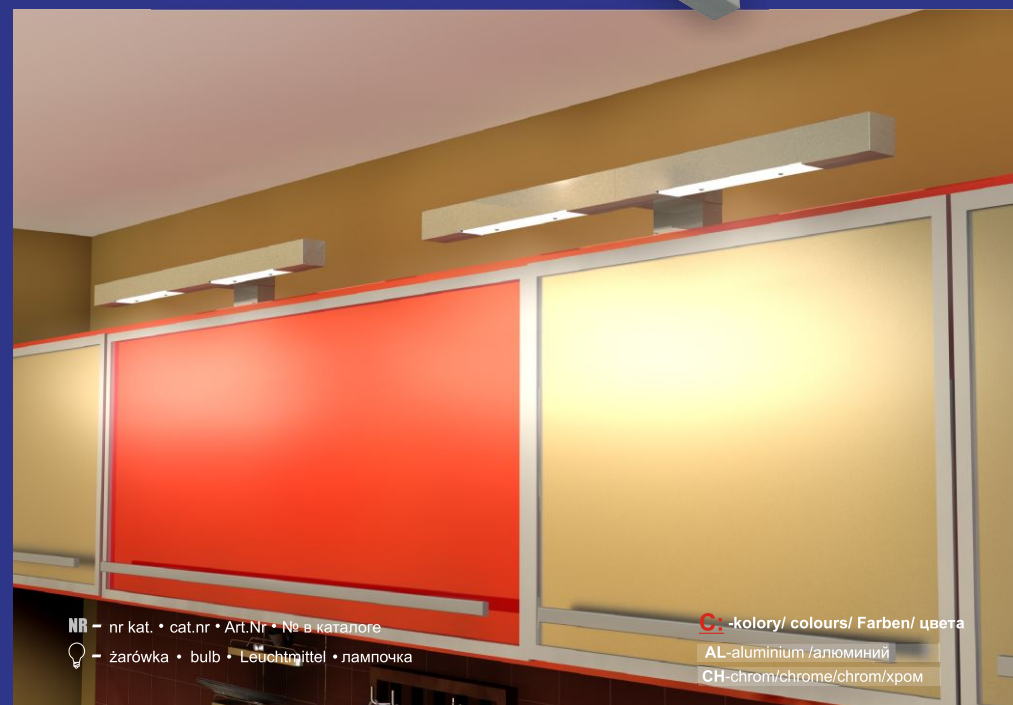
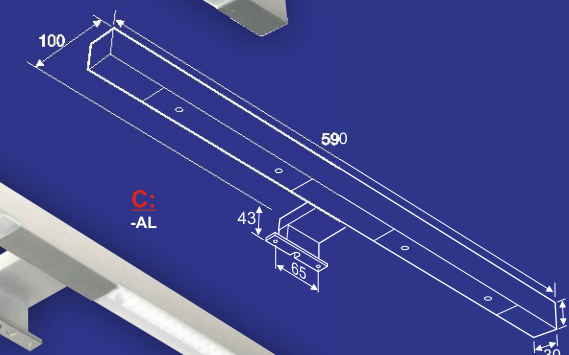

NR - nr kat. • cat.nr • Art.Nr • № в каталоге

- żarówka • bulb • Leuchtmittel • лампочка

C: -kolory/ colours/ Farben/ цвета

AL-aluminium /алюминий

CH-chrom/chrome/хром/хром



- G4** -klosz szklany, żarówka G4 10 lub 20W/12V, kabel dł. 10cm z wtykiem AMP  
 -glass lampshades, bulb G4 10 or 20W/12V, set includes 10 cm cable with AMP plug  
 -Glasschirm, Leuchtmittel G4 10 oder 20W/12V mit 10cm Kabel und AMP Kontakt  
 -стеклянный плафон, лампочка G4 10 или 20Вт./12V с кабелем длиной 10 см. с соединителем AMP
- LED** - możliwe źródło światła LED G4 1,4W/12V DC, komplet z kablem dł. 2m z wtykiem  
 - possibility of using the LED lamp G4 1.4W/12V DC, set includes 2m cable, with plug  
 - möglichkeit des Anwenden die Leuchtmittel LED G4 1.4W/12V DC, Komplet mit 2m Kabel und Kontakt  
 - возможный источник света LED лампочка G4 1,4Вт./12V DC, в комплекте с кабелем длиной 2м. с соединителем

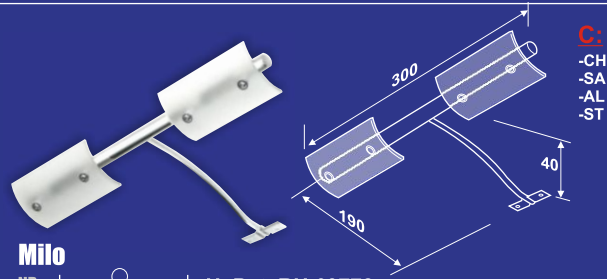

- C:** -kolory/ colours/ Farben/ цвета
- ST**-stal drapana/scratched steel/  
 Stahl gebuerstet/сталь
- CH**-chrom/chrome/chrom/хром
- AL**-aluminium /алюминий
- SA**-satyna/satin/nickel mat /сатин
- NR** - nr kat. • cat.nr • Art.Nr • № в каталоге  
 - żarówka • bulb • Leuchtmittel • лампочка



**LED**

**TRIGA**

NR	
TGLED	1,4W/12V DC

**LED: BI**  
 komplet z kablem 2m  
 set includes 2m cable  
 Komplet mit 2m Kabel  
 в комплекте с кабелем длиной 2м.

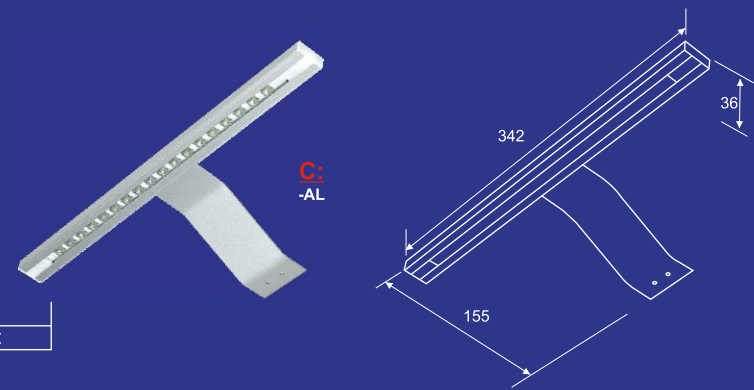

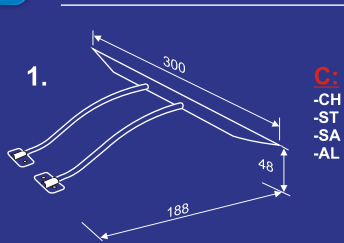

C:  
-CH  
-ST  
-SA  
-AL

U. Pat. W 112577

**Trio**

NR	Light bulb icon
TRJ/...	G4 2x max 20W/12V

-kabel dł. 10cm z wtykiem AMP  
 set includes 10cm cable with AMP plug  
 10cm Kabel und AMP Kontakt  
 с кабелем длиной 10 см. с соединителем AMP

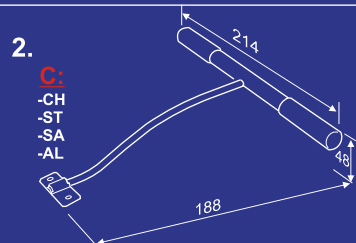

C:  
-CH  
-ST  
-SA  
-AL

**Duo**

NR	Light bulb icon
DU/...	G4 2x max 20W/12V

-2x klosz rurkowy, kabel dł. 10cm z wtykiem AMP  
 -2x tube lampshades, set includes 10 cm cable with AMP plug  
 -2x Glasrohr, mit Kabel und AMP Kontakt  
 -2x трубочный плафон с кабелем длиной 10 см. с соединителем AMP

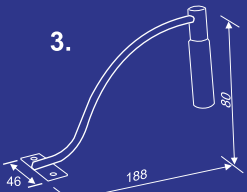

C:  
-CH  
-SA  
-AL

**Tukan**

NR	Light bulb icon
TU/...	G4 1x max 20W/12V



klosze szklane  
 glass lampshades  
 Glasschirme  
 стеклянные плафоны

-klosz rurkowy, kabel dł. 10cm z wtykiem AMP  
 -tube lampshades, set includes 10 cm cable with AMP plug  
 -Glasrohr, mit Kabel und AMP Kontakt  
 -трубочный плафон с кабелем длиной 10 см. с соединителем AMP

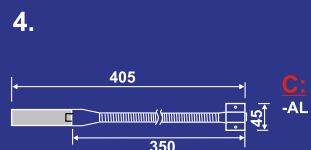

C:  
-AL

**Tukan-G**

NR	Light bulb icon
TU-G/...	G4 1x max 20W/12V

-klosz rurkowy, kabel dł. 10cm z wtykiem AMP  
 -tube lampshades, set includes 10 cm cable with AMP plug  
 -Glasrohr, mit Kabel und AMP Kontakt  
 -трубочный плафон с кабелем длиной 10 см. с соединителем AMP



C: -kolory/ colours/ Farben/ цвета

- ST-stal drapana/scratched steel/ Stahl gebuerstet/сталь
- CH-chrom/chrome/chrom/хром
- SA-satyna/satin/nickel mat/сатин
- AL-aluminium/алюминий
- AN-antyk/antique/antik/антик

NR - nr kat. • cat.nr • Art.Nr  
 № в каталоге

Light bulb icon - żarówka • bulb • Leuchtmittel  
 лампочка

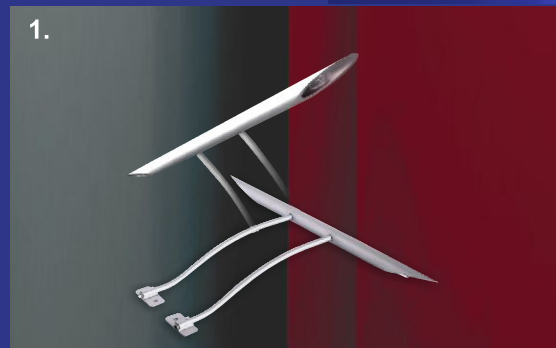
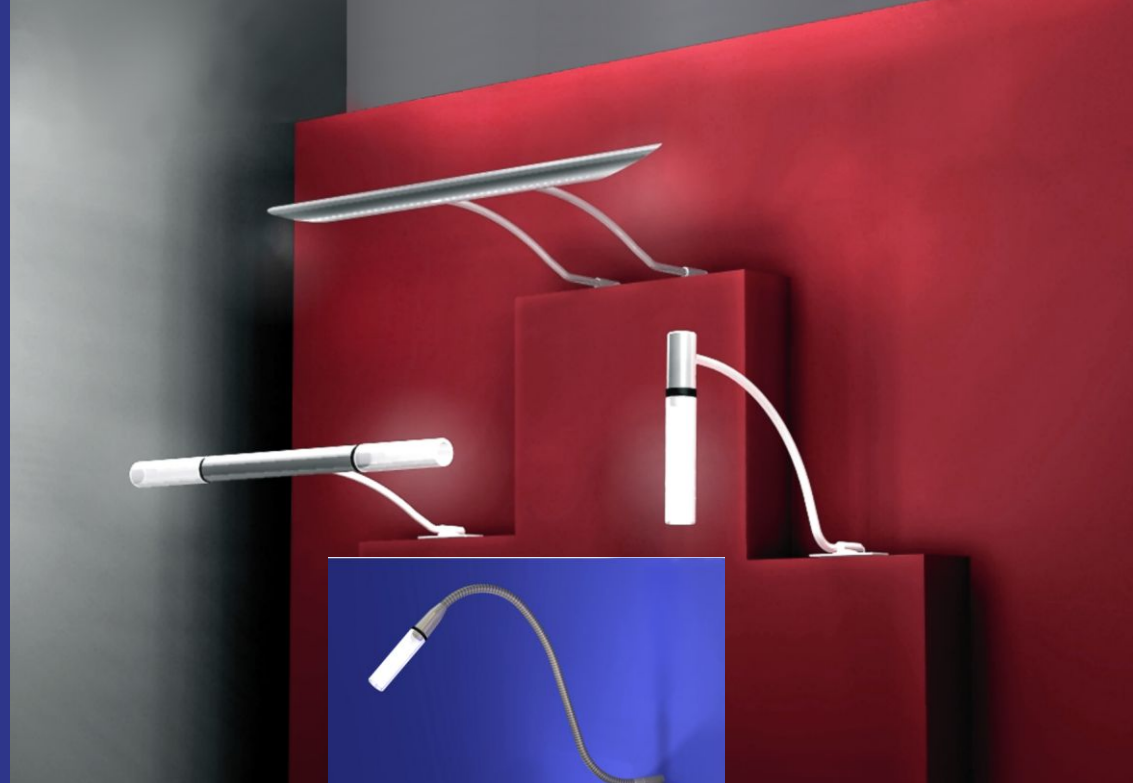

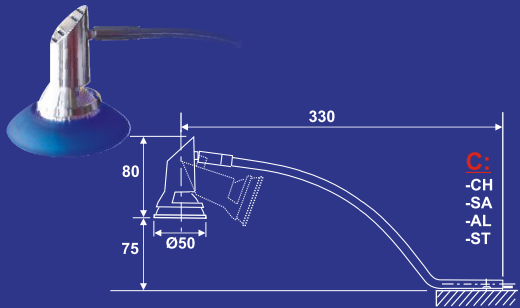

**Mirlo**

NR	
MI/...	MR16 1x max 20W/12V



klosze szklane K-P/...  
 glass lampshades K-P/...  
 Glasschirm K-P/...  
 стеклянный плафон K-P/...

komplet z kablem 10cm, system AMP  
 set includes 10cm cable, AMP system  
 Komplett mit 10cm Kabel, AMP systeme  
 комплект с кабелем длиной 10см. Система AMP

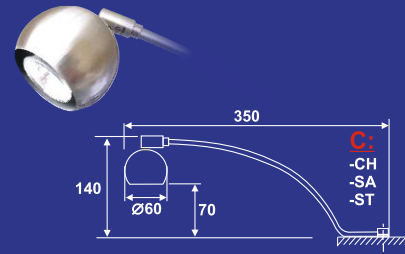

**Kula**

NR	
KU/...	MR11 1x max 20W/12V



**Duomi**

NR	
D/230V/...	G9 2x max 40W/230V



kabel dł. 10cm  
 set includes 10cm  
 10cm Kabel  
 с кабелем длиной 10 см.

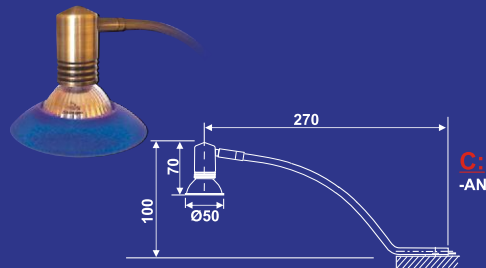
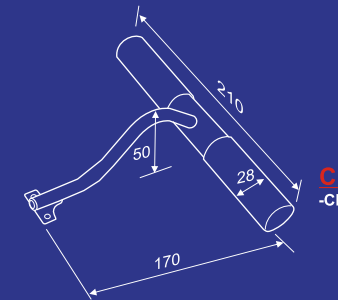

**Apollo**

NR	
AP/...	MR16 1x max 20W/12V



klosze szklane K-P/...  
 glass lampshades K-P/...  
 Glasschirm K-P/...  
 стеклянный плафон K-P/...

komplet z kablem 10cm, system AMP  
 set includes 10cm cable, AMP system  
 Komplett mit 10cm Kabel, AMP systeme  
 комплект с кабелем длиной 10см. Система AMP

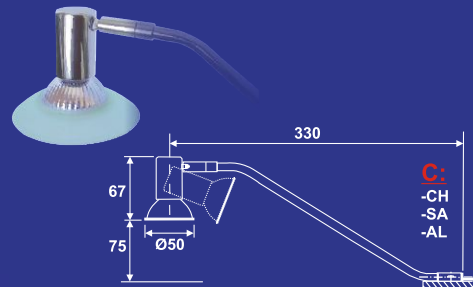

**Loft**

NR	
LO/...	MR16 1x max 20W/12V



klosze szklane K-P/...  
 glass lampshades K-P/...  
 Glasschirm K-P/...  
 стеклянный плафон K-P/...



**C:** -kolory/ colours/ Farben/ цвета

- ST-stal drapana/scratched steel/ Stahl gebuerstet/сталь
- CH-chrom/chrome/chrom/хром
- SA-satyna/satin/nickel mat/сатин
- AL-aluminium/алюминий
- AN-antyk/antique/antik/антик

NR - nr kat. • cat.nr • Art.Nr  
 № в каталоге

- żarówka • bulb • Leuchtmittel • лампочка



**C:** -kolory/ colours/ Farben/ цвета

- CH-chrom/chrome/chrom/хром

- żarówka • bulb • Leuchtmittel • лампочка

NR - nr kat. • cat.nr • Art.Nr • № в каталоге

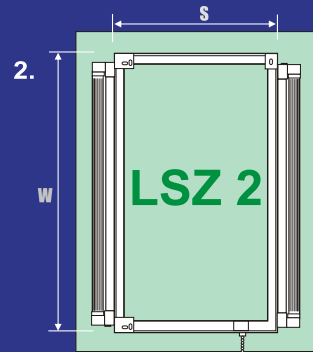
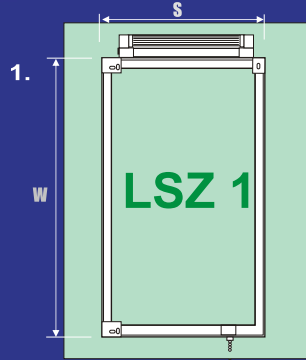

**LSZ 1**

NR	S	W	Light
LSZ 1 320/320	320 mm	320 mm	1xT5 6W
LSZ 1 320/620	320 mm	620 mm	1xT5 6W
LSZ 1 620/320	620 mm	320 mm	1xT5 13W
LSZ 1 620/620	620 mm	620 mm	1xT5 13W
LSZ 1 960/320	960 mm	320 mm	1xT5 21W
LSZ 1 960/620	960 mm	620 mm	1xT5 21W

**LSZ 2**

NR	S	W	Light
LSZ 2 320/320	320 mm	320 mm	2xT5 6W
LSZ 2 320/620	320 mm	620 mm	2xT5 13W
LSZ 2 320/960	320 mm	960 mm	2xT5 21W
LSZ 2 620/320	620 mm	320 mm	2xT5 6W
LSZ 2 620/620	620 mm	620 mm	2xT5 13W
LSZ 2 620/960	620 mm	960 mm	2xT5 21W
LSZ 2 960/320	960 mm	320 mm	2xT5 6W
LSZ 2 960/620	960 mm	620 mm	2xT5 13W
LSZ 2 960/960	960 mm	960 mm	2xT5 21W

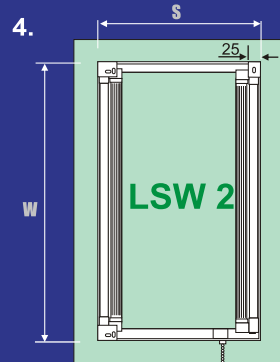
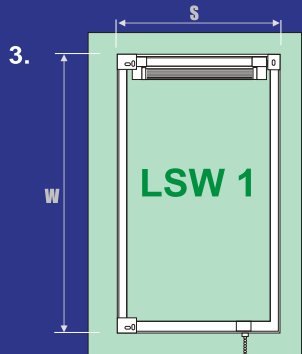

**LSW 1**

NR	S	W	Light
LSW 1 450/620	450 mm	620 mm	1xT5 6W
LSW 1 750/620	750 mm	620 mm	1xT5 13W
LSW 1 1100/620	1100 mm	620 mm	1xT5 21W

**LSW 2**

NR	S	W	Light
LSW 2 450/750	450 mm	750 mm	2xT5 13W
LSW 2 450/1100	450 mm	1100 mm	2xT5 21W
LSW 2 750/750	750 mm	750 mm	2xT5 13W
LSW 2 750/1100	750 mm	1100 mm	2xT5 21W

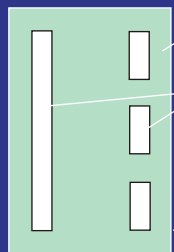

powierzchnia nieprzepuszczająca światła (lustro)  
the opaque surface (mirror)  
die Fläche durchlassen das Licht nicht (der Spiegel)  
поверхность не пропускающая света (зеркало)

powierzchnia przepuszczająca światło (szkło piaskowe)  
the transparent surface (sand glass)  
die Fläche durchlassen das Licht (Sandgestrahl Glass)  
поверхность пропускающая свет (стекло)

różne kształty przezroczystych powierzchni  
the forms of the transparent surface can be different  
die Formen der klar Fläche sind verschieden  
разные формы прозрачных поверхностей

min 150mm

odległość szyby od ściany 15mm  
wall-mirror distance 15mm

- NR** - nr kat. • cat.nr • Art.Nr • № в каталоге
- S** - szerokość • width • Weide • ширина
- W** - wysokość • height • Höhe • высота
- Light - żarówka • bulb • Leuchtmittel • лампочка

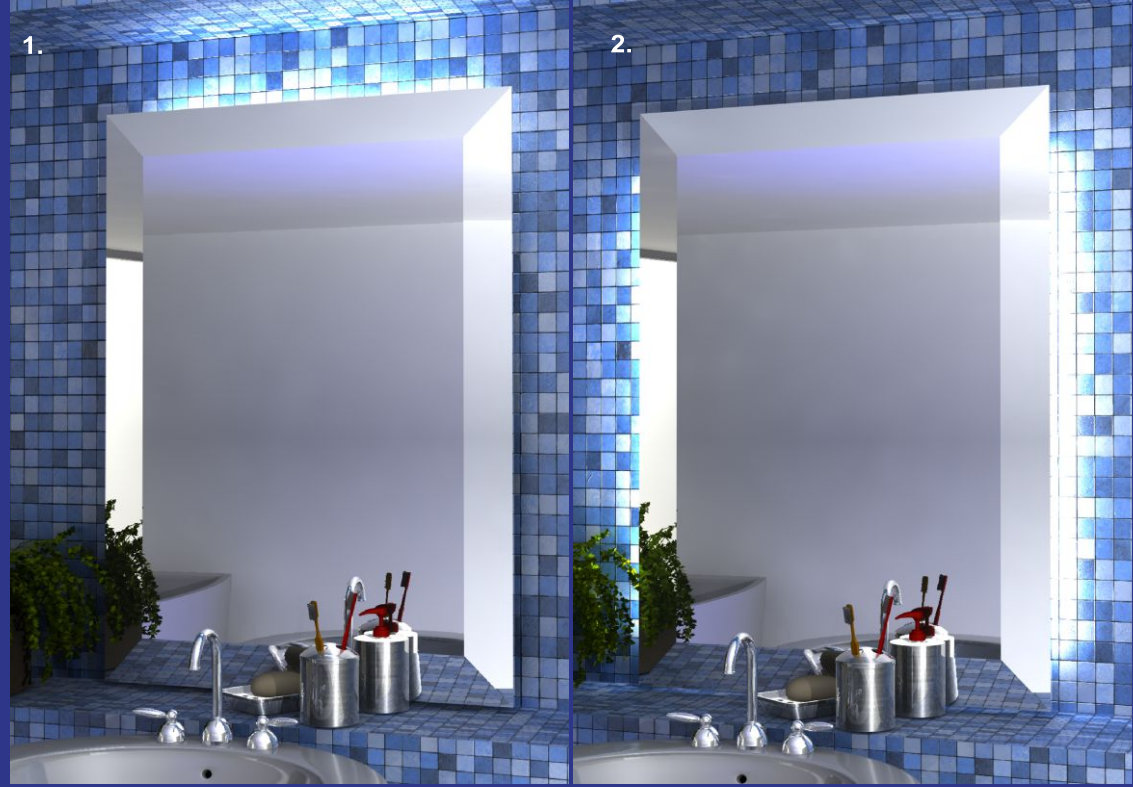

**1. LED**

zasilacz 8W/12V wraz z kablem zasilającym  
dł. 1,75m i wyłącznikiem przelotowym

NR	(W)	
	min-max	
Z-LED/8W	0-8	230V AC/12V DC

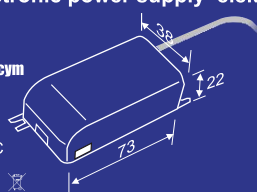

**2. LED**

zasilacz wtyczkowy  
LED 5W/12V

NR	(W)	
	min-max	
ZW-LED	0-5	230V AC/12V DC

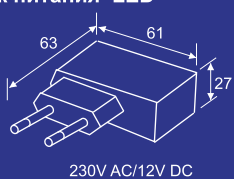

TRANSFORMATORY MECHANICZNE - ELECTROMECHANIC TRANSFORMERS - ELEKTROMECHANISCHE TRAFOS - механические трансформаторы

**3.**

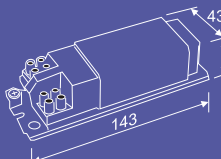

**TRM/60**

230V/11,5V

NR	(W)	
	min-max	
TRM/60	0-60	



**4.**

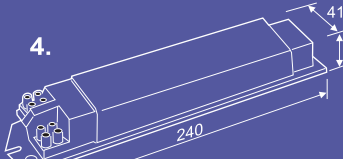

**TRM/105**

230V/11,5V

NR	(W)	
	min-max	
TRM/105	0-105	



TRANSFORMATORY ELEKTRONICZNE - ELECTRONICS TRANSFORMERS - ELEKTRONISCHE TRAFOS - электронные трансформаторы

**5.**

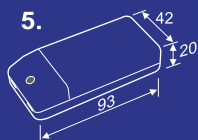

**MET60E**

plaski/ flat/ eben 230V/11,4V

NR	(W)	
	min-max	
MET60	10-60	



**6.**

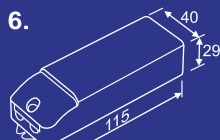

**TRE/105**

230V/11,4V

NR	(W)	
	min-max	
TRE/105	20-105	



**7.**

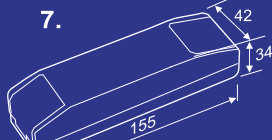

**KTL/150**

230V/11,4V

NR	(W)	
	min-max	
KTL/150	40-150	



TRANSFORMATORY ELEKTRONICZNE VDE  
ELECTRONICS TRANSFORMERS VDE  
ELEKTRONISCHE TRAFOS VDE  
электронные трансформаторы VDE

**9.**

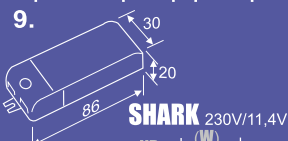

**SHARK**

230V/11,4V

NR	(W)	
	min-max	
TCIS/60	10-60	



**10.**

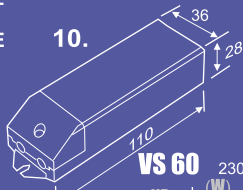

**VS 60**

230V/11,4V

NR	(W)	
	min-max	
VS/60	20-60	



**8.**

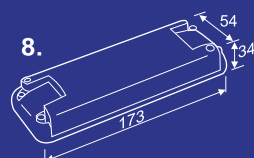

**TRE/250**

230V/11,4V

NR	(W)	
	min-max	
TRE/250	40-250	



WYŁĄCZNIKI DOTYKOWE- TOUCH SWITCH-BERUEHRUNGSSCHALTER -сенсорные выключатели

**11.**

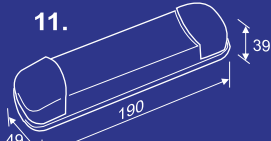

**WOLF**

z wyłącznikiem dotykowym i ściemniaczem  
with touch switch and dimmer

Elektronischer Trafo mit Beruehrungsschalter  
с сенсорным выключателем и диммером

NR	(W)	
	min-max	
TCID/60	20-60	
TCID/105	35-105	

230V/0-12V

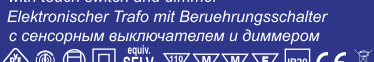

**12.**

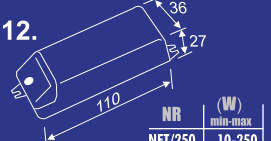

**NFT 250**

wyłącznik dotykowy  
touch switch

Beruehrungsschalter  
сенсорный выключатель

NR	(W)	
	min-max	
NFT/250	10-250	

230V/0-230V



**1.**

-zasilacz 12V DC/8W wraz z kablem zasilającym dł. 1,75m i wyłącznikiem przelotowym  
-electronic power supply 12V DC/8W with feeder cable 1,75m, passage switch  
-elektron. Trafo 12V DC/8W, Anschluss-kabel 1,75m mit Schalter  
-Источник питания 12VDC/8Вт. вместе с сетевым кабелем 1,75 м. и выключателем «бра»

**2.**

-zasilacz wtyczkowy 12V DC/5W łącznie z kablem o dł. 1,5m.  
-AC/DC Wall Plug adapter 12V DC/5W with feeder cable 1,5m.  
-AC/DC Adapter 12V DC/5W, Anschluss-kabel 1,5m.  
-штупсельный источник питания 12V DC/5Вт. вместе с кабелем 1,5 м.

**3.**

**4.**

**5.**

**6.**

**7.**

**8.**

**9.**

**10.**

**11.**

**12.**

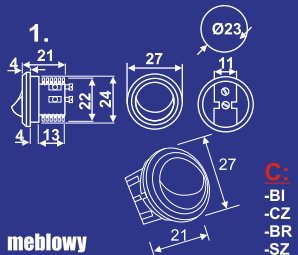

**meblowy**  
furniture circular switch  
**Moebelschalter**  
мебельный

NR  
W/M/... 10(4)A/250V~



C:  
-BI  
-CZ  
-BR  
-SZ

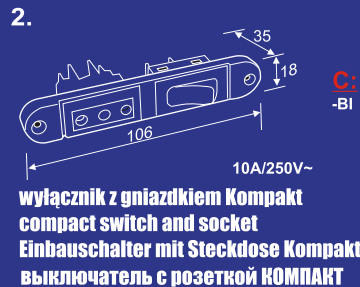

**wyłącznik z gniazdkiem Kompakt**  
compact switch and socket  
**Einbauswitcher mit Steckdose Kompakt**  
выключатель с розеткой КОМПАКТ

NR  
W/K/... 10A/250V~

C:  
-BI



**łańcuszkowy**  
chainlet switch  
**Zugschalter**  
шнурковый

NR  
W/L/... 3A/250V~



C:  
-CH  
-ZL



**przelotowy**  
passage switch  
**Kabelschalter**  
«Бра»

NR  
W/P/... 2,5A/250V~



C:  
-BI  
-CZ

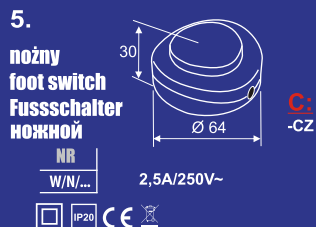

**nożny**  
foot switch  
**Fussschalter**  
ножной

NR  
W/N/... 2,5A/250V~



C:  
-CZ



**do drzwi przesuwnych**  
furniture-door switch  
**Druckschalter**  
прижимной

NR  
W/DO/... 2(1)A/250V~



C:  
-CZ

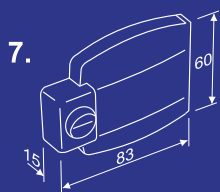

**gniazdka łazienkowe**  
bathroom socket  
**Bad Steckdose**  
розетка для ванной

wyłącznik/ switch/ Schalter/ выключатель 6(2)A/250V~  
gniazdka/ socket/ Steckdose/ розетка 16A/250V~

NR  
Schuko GWS  
bolec GWB



C:  
-BI

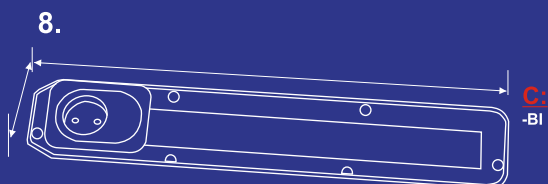

**listwa do szafek, z gniazdkiem i wyłącznikiem, IP23**  
bathroom cabinet cover, IP23  
**die Decke der Badezimmerschränken**  
панель с розеткой IP23

wyłącznik/ switch/ Schalter/ выключатель 6(2)A/250V~  
gniazdka/ socket/ Steckdose/ розетка 16A/250V~

NR  
LZG



C:  
-BI



C: -kolory/ colours/ Farben/ цвета

- CZ-czarny/ black/ schwarz/ черный
- BI-biały/ white/ weiss/ белый
- BR-brązowy/ brown/ braun/ коричневый
- SZ-szary/ grey/ grau/ серый
- CH-chrom/ chrome/ chrom/ хром
- ZL-złoty/ gold/ gold/ золото

NR - nr kat. • cat.nr • Art.Nr • № в каталогe

**1. rozdzielacz LED**  
LED-adapter  
LED-Verteiler  
разделитель LED

NR	IL
R-LED/5	5

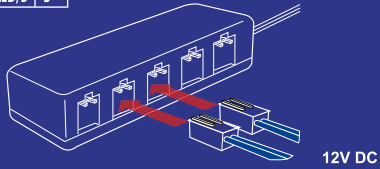

**3. rozdzielacz AMP**  
AMP-adapter  
AMP-Verteiler  
разделитель AMP  
2x 0,75mm<sup>2</sup>

NR	IL
AMP/R1	1
AMP/R2	2
AMP/R3	3
AMP/R4	4
AMP/R5	5

Schemat łączenia za pomocą rozdzielacza AMP

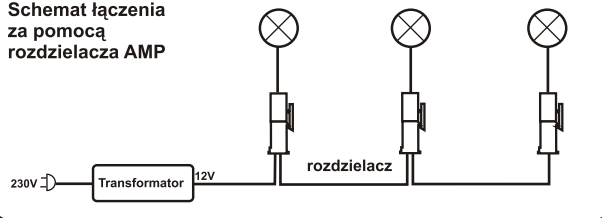

**2. listwa AMP 12V, kabel 14cm**  
AMP kompakt adapter 12V, cable 14cm  
AMP kompakt-Verteiler 12V, mit 14cm Kabel

NR
AMP/RK3
AMP/RK6

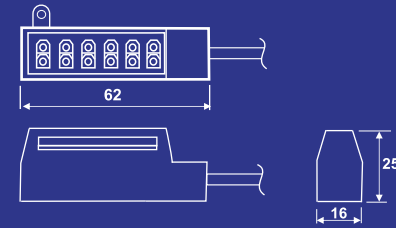

**4. przedłużacz AMP**  
AMP extension cord cable  
AMP-Verlängerung  
удлинитель AMP  
2x 0,75mm<sup>2</sup>

NR	D
AMP/P1	1m
AMP/P2	2m

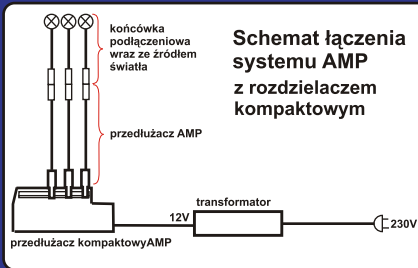

Schemat łączenia systemu AMP z rozdzielaczem kompaktowym

**Kable zasilające/ Wiring/ Verkabelung/ Сетевые кабели**

**5. -kabel sieciowy z wtykiem**  
-feeder cable  
-Anschluss-kabel  
-Сетевой кабель с вилкой

NR	D
KZ/2	2m
KZ/3	3m
KZ/4	4m
KZ/5	5m

2 x 0,75mm<sup>2</sup>

W ofercie kolor kabla: biały i czarny  
Cable colour : white and black  
In den Farben: weiss, schwarz  
Предложение по цветам кабеля:  
белый и черный



**6. -kabel sieciowy z wyłącznikiem przelotowym**  
-feeder cable with passage switch  
-Anschluss-kabel mit Schalter  
-Сетевой кабель с выключателем «бра»

NR	D
KZ/2WP	2m
KZ/3WP	3m
KZ/5WP	5m

2 x 0,75mm<sup>2</sup>

W ofercie kolor kabla: biały i czarny  
Cable colour : white and black  
In den Farben: weiss, schwarz  
Предложение по цветам кабеля:  
белый и черный



**7. -kabel sieciowy z wyłącznikiem nożnym**  
-feeder cable with foot switch  
-Anschluss-kabel mit Fusschalter  
-Сетевой кабель с ножным выключателем

NR	D
KZ/4WN	4m

2 x 0,75mm<sup>2</sup>

W ofercie kolor kabla: biały i czarny  
Cable colour : white and black  
In den Farben: weiss, schwarz  
Предложение по цветам кабеля:  
белый и черный

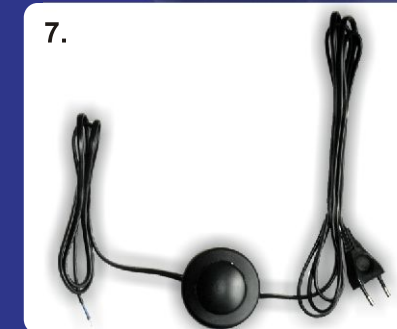
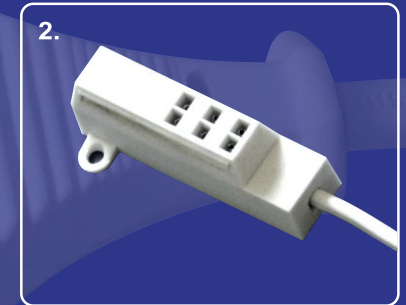

IL - ilość • quantity • Menge • количество

D - długość • length • Leange • длина

NR - nr kat. • cat.nr • Art.Nr • № в каталоге

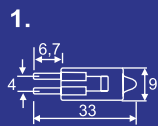

**G4** 10, 20W/12V  
żarówka halogenowa  
halogen bulb  
Stiftsockel Leuchte  
галогенная лампочка

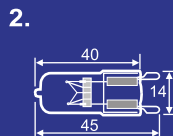

**G9** 25, 40W/230V  
żarówka halogenowa  
halogen bulb  
Stiftsockel Leuchte  
галогенная лампочка

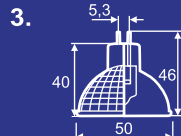

**MR16** 20, 35, 50W/12V  
żarówka halogenowa  
halogen bulb  
Kaltlichtspiegel Leuchten  
галогенная лампочка

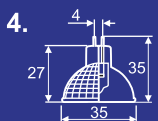

**MR11** 20W/12V  
żarówka halogenowa  
halogen bulb  
Kaltlichtspiegel Leuchten  
галогенная лампочка

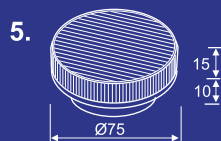

**MICRO-LYNX F** 7W/230V  
światłówka do opraw  
fluorescent lamp  
Leuchtstoffrohren  
люминесцентная лампа  
для светильников

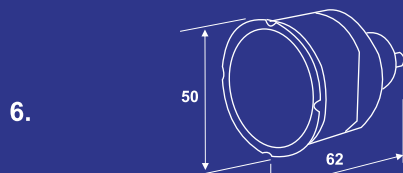

**GU10S** 7W/230V  
światłówka kompaktowa GU10  
compact fluorescent lamp GU10  
kompakte Leuchtstofflampe GU10  
люминесцентная лампа GU10

NR	W
GU10S/7	7W
GU10S/9	9W
GU10S/11	11W



**T4**  
światłówka T4  
fluorescent lamp T4  
Leuchtstofflampe T4  
люминесцентная лампа T4

NR	W
T4/6	6W
T4/8	8W
T4/16	16W
T4/20	20W
T4/30	30W

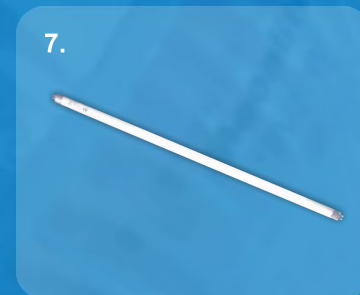

### 1. Ø50

nóżka okrągła ze stali nierdzewnej  
circular foot made of stainless steel  
Fuss Rund aus Edelstahl  
круглая ножка из нержавеющей стали

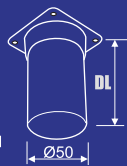

NR	DL
NO50-6/ST	60mm
NO50-10/ST	100mm
NO50-15/ST	150mm

### 3. 40x40

noga narożna ze stali nierdzewnej  
square foot made of stainless steel  
Fuss Eckig aus Edelstahl  
угловая нога из нержавеющей стали

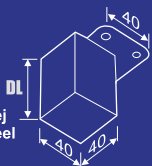

NR	DL
NNK40-6/ST	60mm
NNK40-10/ST	100mm
NNK40-15/ST	150mm

### 5. 80x80

noga narożna ze stali nierdzewnej  
square foot made of stainless steel  
Fuss Eckig aus Edelstahl  
угловая нога из нержавеющей стали

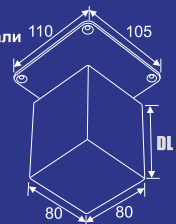

NR	DL
NNK80-3/ST	30mm
NNK80-6/ST	60mm
NNK80-10/ST	100mm
NNK80-71/ST	710mm
NNK80-71R/ST	710mm

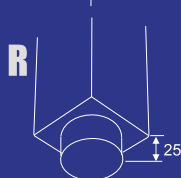

### 2. 40x40

nóżka kwadratowa ze stali nierdzewnej  
square foot made of stainless steel  
Fuss Eckig aus Edelstahl  
квадратная ножка из нержавеющей стали



NR	DL
NK40-6/ST	60mm
NK40-10/ST	100mm
NK40-15/ST	150mm

### 4. 60x60

noga narożna ze stali nierdzewnej  
square foot made of stainless steel  
Fuss Eckig aus Edelstahl  
угловая нога из нержавеющей стали

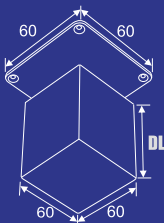

NR	DL
NNK60-3/ST	30mm
NNK60-6/ST	60mm
NNK60-10/ST	100mm
NNK60-71/ST	710mm
NNK60-71R/ST	710mm

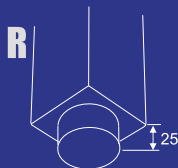

### 6. 100x100

noga narożna ze stali nierdzewnej  
square foot made of stainless steel  
Fuss Eckig aus Edelstahl  
угловая нога из нержавеющей стали

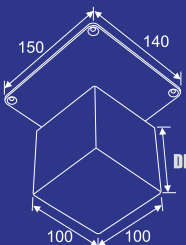

NR	DL
NNK100-3/ST	30mm
NNK100-6/ST	60mm
NNK100-10/ST	100mm
NNK100-71/ST	710mm
NNK100-71R/ST	710mm

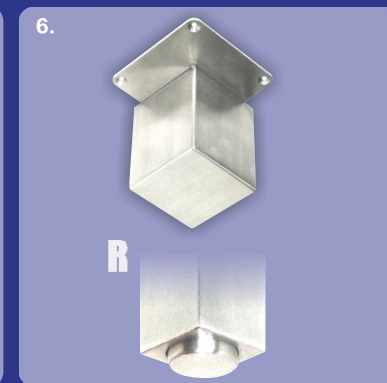
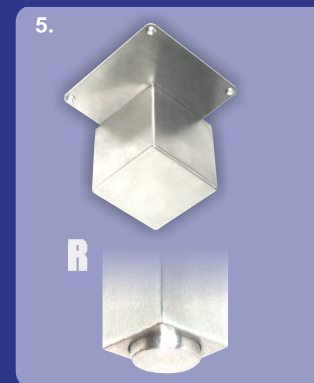
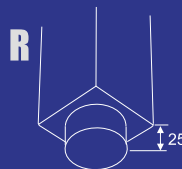

**R** - regulowana • regulation • Regelung • регулируемая

**NR** - nr kat. • cat.nr • Art.Nr • № в каталоге

**DL** - długość • length • Leange • длина

# BIOKOMINKI

Biokominek jest innowacyjną konstrukcją, przeznaczoną do stosowania wewnątrz pomieszczeń posiadających normalny system wentylacji (nie mogą być to pomieszczenia całkowicie szczelne) i nie wymagają komina do odprowadzania spalin. Są to kominki bez komina. Połączenie prostych kształtów z nowoczesną stylistyką tworzy przyjemną atmosferę i znacznie zwiększają walory estetyczne pomieszczenia. Jest to przede wszystkim osiągnięte dzięki występowaniu prawdziwego żywego ognia, który nie jest statyczny jak w przypadku świec. Fakt budowy biokominka z metali szlachetnych wysokiej jakości w połączeniu z ciekawą kolorystyką sprawia, że pomieszczenie nabiera nowoczesnego charakteru i elegancji. Prosty montaż i możliwość wielorakiego zastosowania przemawia na zdecydowaną korzyść stosowania tego wyrobu. Możliwe jest także wbudowanie wkładu w klasyczne kształty kominków. Nie bez znaczenia jest też fakt poprawy bilansu cieplnego. Biokominek jest wydajnym źródłem ciepła i jest atrakcyjnym uzupełnieniem standardowego systemu grzewczego.

Tradycyjne systemy grzewcze wysuszają powietrze obniżając komfort wdychanego powietrza. Biokominki produkowane przez firmę MCJ<sup>®</sup> wyposażone są w zintegrowany system nawilżania powietrza (System zgłoszony w Urzędzie Patentowym). Pałac w biokominku można jednocześnie dodatkowo dość intensywnie nawilżać pomieszczenie. Do wody będącej w nawilżaczu możemy dolać olejki zapachowe lub inne preparaty do aromaterapii które zwiększają komfort powietrza w pomieszczeniu. Dzięki temu w czasie normalnego przebywania w pomieszczeniu możemy poddać się aromaterapii nie tracąc dodatkowego czasu.

Przykładowa kaloryczność podczas spalania :

Biopalix	ok.30 MJ/kg
drewno	12 MJ/kg
benzyna	45 MJ/kg
węgiel kamienny	24 MJ/kg

MCJ<sup>®</sup>  
Biokominki



# BIO CHIMNEY

Bio chimney is an innovation used indoors with regular ventilation systems ( not to be used in completely air-closed buildings). Bio chimney does not require a chimney. The combination of simple elements and stylish finish gives pleasant feeling and brings ambience. This is reached due to a live fire which is not steady (like candle fire). Bio chimney is made of high quality stainless steel and other elements with eye-catching colors. Any room takes on a modern look and elegance. Bio chimney is simple in assembly and various in utilization. It can be built into any classic shapes or frames of fireplaces. Bio chimney is an efficient source of heat and an attractive addition to any heating system. Traditional heating systems tend to dry out the air reducing the quality of comfort and that of inhaled air. Bio chimneys made by MCJ® company come with integrated air-moisturizing system (patented system). While enjoying the heat coming from bio chimney, the system moistures the air around at the same time. Adding fragrance or other aromatherapy oils to water container increases comfort and pleasure.

## CONSUMPTION EXAMPLES:

Biopalix	approx. 30MJ/kg
Wood	12MJ/kg
Fuel	45MJ/kg
Coal	24MJ/kg

# BIOKAMIN

Biokamine sind eine innovative Erfindung, welche ausschließlich für den Innenbetrieb hergestellt wurden: der Kamin für JEDERMANN! Biokamine werden mit Bioethanol betrieben, sodass kein Rauch und keine Russpartikel entstehen und somit kein Kamin benötigt wird. In den Biokaminen wurde das Holz durch den flüssigen Öko-Brennstoff Bioethanol ersetzt. Bei der Verbrennung entsteht weder Rauch noch Geruch, trotzdem hat das Feuer eine natürliche Farbe und Form. Für die Nutzung des Biokamins ist kein Schornsteinanschluss erforderlich. Kein Schmutz, Staub, Asche und Russ. Kein Holz hacken, nur noch Brennstoff nachfüllen. Durch ihre moderne und sehr elegante Art und Bauweise aus hochwertigem Metall in Verbindung mit modernen Farben erhält man eine ruhige, entspannte und stressfreie Atmosphäre sowie einen sehr modernen und eleganten Raum. Durch das Feuer erhält man außerdem ein richtiges „Kamin-Feeling“. Da die Wandbefestigung sehr einfach ist, kann man diese an beliebigen Orten, in beliebiger Höhe und in beliebiger Art und Weise aufhängen. Auch Einbauten in klassische Kamine sind durchaus möglich. Nicht zu vergessen ist auch die Bilanz der Wärmeabgabe, da Biokamine eine gewisse Menge an Wärme abgeben! Standardheizkörper trocknen die Raumluft sehr aus und verschlechtern das gesamte Raumklima sowie Allgemeinbefinden. Unsere Biokamine, Biokamine von MCJ®, wurde so hergestellt, dass die Luftfeuchtigkeit und das Raumklima konstant bestehen bleibt (*Patentiertes System!!!*) Um ein noch besseres Raumklima zu erhalten, ist es durchaus möglich aromatische Öle hinzuzufügen, sodass dieses noch einmal an Qualität gewinnt. So erhalten Sie eine angenehme und wirksame Aromatherapie ohne dabei, meist kostbare, Zeit zu verlieren.

## Beispiele von Brennwerten

Brennstoff Biopalix	ca.30 MJ/kg
Brennholz	12 MJ/kg
Benzin	45 MJ/kg
Steinkohle	24 MJ/kg





MCJ

44-293 Gaszowice

ul. Sumińska 2a

tel: +48/32/423 45 44

tel: +48/32/422 92 63

fax: +48/32/423 92 86

katalog: [www.mcj.pl](http://www.mcj.pl)

adres e-mail: [mcj@mcj.pl](mailto:mcj@mcj.pl)

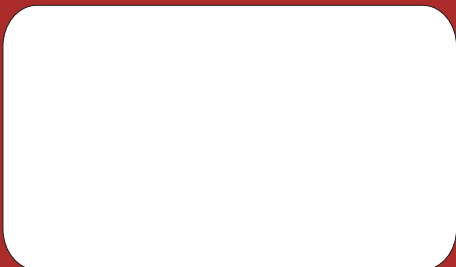
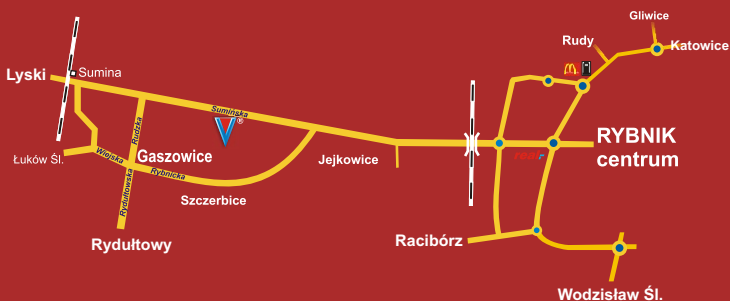

BIOKOMINKI

# BIOKOMINKI

Od wieków jedyną w swoim rodzaju wspaniałą atmosferę przytulności, komfortu i bezpieczeństwa tworzyło ognisko oraz rozchodzący się od niego blask. Nie wszyscy jednak mają możliwość wykonania tradycyjnego kominka ze względu na ograniczenia nałożone przez przewód kominowy i nie zawsze satysfakcję daje imitacja ognia z kominków elektrycznych. Rozwiązaniem jest żywy ogień płonący w Biokominkach.

Biokominki nie wymagają przewodu kominowego a wystarczy jedynie zwykły system wentylacyjny. W produkowanych przez MCJ<sup>®</sup> Biokominkach płonie żywy, naturalny ogień, który dzięki połączeniu stali szlachetnej, szkła hartowanego i kamienia daje niepowtarzalny efekt. Nowoczesne wzornictwo (projekty Jaco Designe) doskonale dopasowuje się do współczesnych minimalistycznych jak i tradycyjnych pomieszczeń. Biokominek oprócz walorów estetycznych jest wydajnym źródłem ciepła, stanowi znakomite uzupełnienie standardowego ogrzewania i jest szczególnie przydatny w okresie wiosny oraz jesieni. W tradycyjnych kominkach do 60% energii cieplnej jest wyprowadzana na zewnątrz przez przewód kominowy, a w biokominkach cała wytworzona energia pozostaje w pomieszczeniu. Tradycyjne systemy grzewcze wysuszają powietrze obniżając komfort wdychanego powietrza. Produkowane przez firmę MCJ<sup>®</sup> Biokominki wyposażone są w zintegrowany system nawilżania powietrza (rozwiązania zgłoszone w Urzędzie Patentowym RP). Paląc w Biokominku można intensywnie nawilżyć powietrze a dodatkowo stosując olejki aromatyczne i zapachowe korzystać z aromaterapii, poprawiając komfort powietrza w pomieszczeniu.

W Biokominkach spalany jest biopłyn BIOPALIX<sup>®</sup>, którego głównym składnikiem jest alkohol etylowy. Jego skład sprawia, że produktem bezdymnego spalania jest para wodna i dwutlenek węgla (podobnie do składu w ludzkim wydychanym powietrzu). W zależności od rodzaju palnika i stopnia jego otwarcia 1l Biopalixu<sup>®</sup> wystarcza na 2 – 5 godzin użytkowania.

Przykładowa kaloryczność podczas spalania:

Biopalix	ok. 30 MJ/kg
Drewno	12 MJ/kg
Benzyna	45 MJ/kg
Węgiel kamienny	24 MJ/kg

# BIOFIREPLACES

## DISCRIPTION

Biofireplace is an innovation used indoors with regular ventilation systems (not to be used in completely air-closed buildings). Biofireplace does not require a chimney. The combination of simple elements and stylish finish gives pleasant feeling and brings ambience. This is reached due to a live fire which is not steady (like candle fire). Biofireplace is made of high quality stainless steel and other elements with eye-catching colors. Any room takes on a modern look and elegance. Biofireplace is simple in assembly and various in utilization. It can be built into any classic shapes or frames of fireplaces. Biofireplace is an efficient source of heat and an attractive addition to any heating system. Traditional heating systems tend to dry out the air reducing the quality of comfort and that of inhaled air. Biofireplaces made by MCJ<sup>®</sup> company come with integrated air-moisturizing system (patented system). While enjoying the heat coming from biofireplace, the system moistures the air around at the same time. Adding fragrance or other aromatherapy oils to water container increases comfort and pleasure.

## OPERATING INSTRUCTIONS

Bio-fluid called BIOPALIX<sup>®</sup> is burnt in biofireplaces, or more specifically, its fumes. The ingredients of BIOPALIX<sup>®</sup> are carefully selected and steam with carbon dioxide become the burning products. Steam causes the increase of humidity and the quantities of carbon dioxide are not hazardous. There is no emission of smoke which usually comes out of conventional fireplaces. On average, 1L of BIOPALIX<sup>®</sup> keeps the flame burning from 2 to 5 hours (burning times vary depending on the kind and openness of burner). In conventional fireplaces up to 60% of heat goes outside through the chimney. In biofireplaces the heat stays inside.

## CONSUMPTION EXAMPLES:

Biopalix	approx. 30 MJ/kg
Wood	12 MJ/kg
Fuel	45 MJ/kg
Coal	24 MJ/kg





# DELTA

Biokominek z nawilżaczem/ Biofireplace with air-moisturizing

Pojemność palnika/ Burner capacity	- 1,4l
Czas spalania/ Burning time	- 1l biopłynu przy maksymalnym otwarciu zasuw -ok. 4,5 godz./ 1 litre of fluid lasts for about 4,5 hours with a fully opened schuter
Moc/ Power	- ok. 1,5 kW/ approx. 1,5 kW
Zużycie powietrza w procesie palenia/ Air consumption during burning	- ok. 1,3m <sup>3</sup> / godzinę (ok. 5,5m <sup>3</sup> / 1l spalania Biopłynu)/ approx. 1,3m <sup>3</sup> /h (approx. 5,5m <sup>3</sup> / 1l bio- fluid)

Pojemność nawilżacza/ Moisturizer capacity	- 1l
--	------

Waga/ Weight	- 8 kg
--------------	--------

### Komplet zawiera/ Set includes:

- biokominek/ biofireplace
- rączka uniwersalna/ universal handle
- 1l płynu Biopalix/ 1l of Biopalix
- pojemnik ułatwiający wlewanie biopłynu do palnika/ container to fill the burner

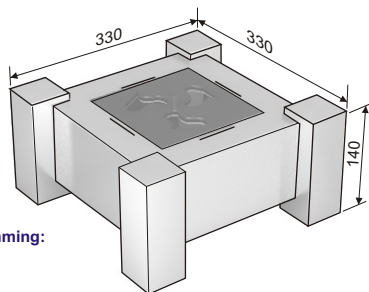

### Wersje wykończenia/ version of the timming:

- piaskowiec/ sandstone
- łupek/ slate
- szkło czarne/ black glass

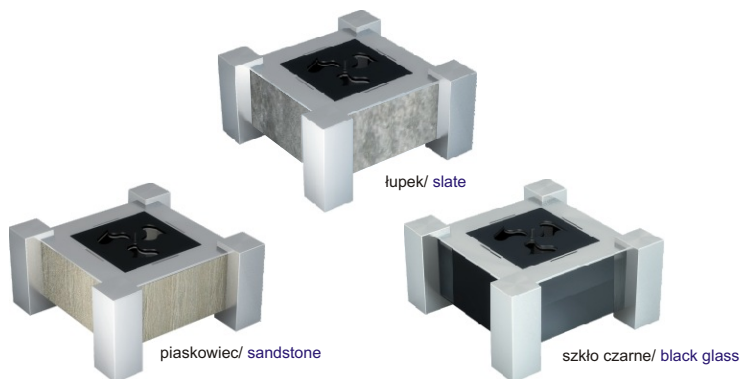

# AURORA

Pojemność palnika/ Burner capacity	- 1,4l
Czas spalania/ Burning time	- 1l biopłynu przy maksymalnym otwarciu zasuw -ok. 4,5 godz./ 1 litre of fluid lasts for about 4,5 hours with a fully opened schuter
Moc/ Power	- ok. 1,5 kW/ approx. 1,5 kW
Zużycie powietrza w procesie palenia/ Air consumption during burning	- ok. 1,3m <sup>3</sup> / godzinę (ok. 5,5m <sup>3</sup> / 1l spalania Biopłynu)/ approx. 1,3m <sup>3</sup> /h (approx. 5,5m <sup>3</sup> / 1l bio- fluid)

Waga/ Weight	- 11,5 kg
--------------	-----------

### Komplet zawiera/ Set includes:

- biokominek/ biofireplace
- rączka uniwersalna/ universal handle
- 1l płynu Biopalix/ 1l of Biopalix
- pojemnik ułatwiający wlewanie biopłynu do palnika/ container to fill the burner

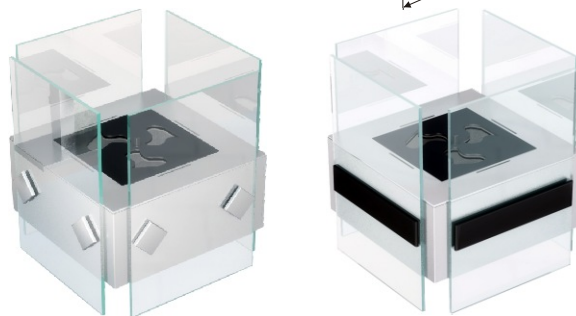
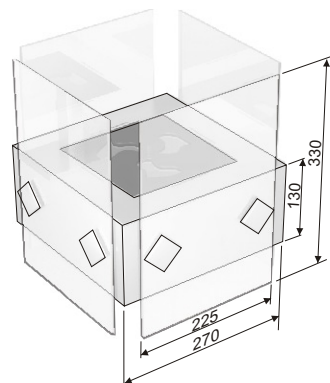



## LONG

Biokominek z nawilżaczem/ Biofireplace with air-moisturizing

<b>Pojemność palnika/ Burner capacity</b>	- 1,4l
<b>Czas spalania/ Burning time</b>	- 1l biopłynu przy maksymalnym otwarciu zasuw -ok. 4,5 godz./ 1 litre of fluid lasts for about 4,5 hours with a fully opened schuter
<b>Moc/ Power</b>	- ok. 1,5 kW/ approx. 1,5 kW
<b>Zużycie powietrza w procesie palenia/ Air consumption during burning</b>	- ok. 1,3m <sup>3</sup> / godzinę (ok. 5,5m <sup>3</sup> / 1l spalania Biopłynu)/ approx. 1,3m <sup>3</sup> /h (approx. 5,5m <sup>3</sup> / 1l bio- fluid)

<b>Pojemność nawilżacza/ Moisturizer capacity</b>	- 1l
---	------

<b>Waga/ Weight</b>	- 22,5 kg
---------------------	-----------

### Komplet zawiera/ Set includes:

- biokominek/ biofireplace
- rączka uniwersalna/ universal handle
- 1l płynu Biopalix/ 1l of Biopalix
- pojemnik ułatwiający wlewanie biopłynu do palnika/ container to fill the burner



### Wersje/ versions:

- bez podstawy/ without base
- z podstawą/ with base

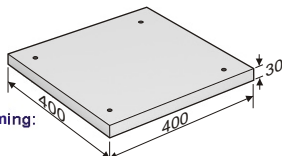

podstawa/ base

### Wersje wykończenia/ version of the timing:

- piaskowiec/ sandstone
- łupek/ slate



6 piaskowiec/ sandstone

łupek/ slate



## ŻAGIEL

Biokominek z nawilżaczem/ Biofireplace with air-moisturizing

<b>Pojemność palnika/ Burner capacity</b>	- 1,5l
<b>Czas spalania/ Burning time</b>	- 1l biopłynu przy maksymalnym otwarciu zasuw -ok. 2 godz./ 1 litre of fluid lasts for about 2 hours with a fully opened schuter
<b>Moc/ Power</b>	- ok. 3 kW/ approx. 3 kW
<b>Zużycie powietrza w procesie palenia/ Air consumption during burning</b>	- ok. 2,75m <sup>3</sup> / godzinę (ok. 5,5m <sup>3</sup> / 1l spalania Biopłynu)/ approx. 2,75m <sup>3</sup> /h (approx. 5,5m <sup>3</sup> / 1l bio- fluid)

<b>Pojemność nawilżacza/ Moisturizer capacity</b>	- 1l
---	------

<b>Waga/ Weight</b>	- 125 kg
---------------------	----------

### Komplet zawiera/ Set includes:

- biokominek/ biofireplace
- rączka uniwersalna/ universal handle
- 1l płynu Biopalix/ 1l of Biopalix
- pojemnik ułatwiający wlewanie biopłynu do palnika/ container to fill the burner

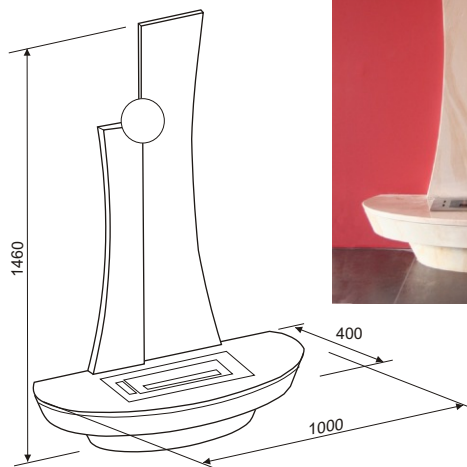
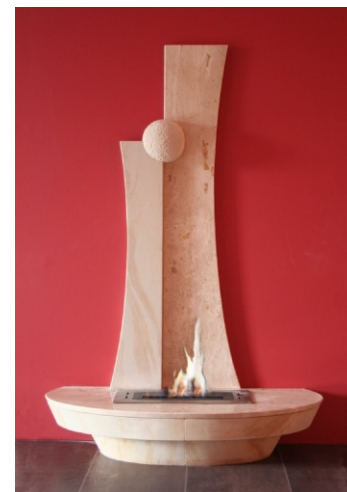



## GRAND-S

Biokominek z nawilżaczem/ Biofireplace with air-moisturizing

<b>Pojemność palnika/ Burner capacity</b>	- 1,5l
<b>Czas spalania/ Burning time</b>	- 1l biopłynu przy maksymalnym otwarciu zasuw -ok. 2 godz./ 1 litre of fluid lasts for about 2 hours with a fully opened schuter
<b>Moc/ Power</b>	- ok. 3 kW/ approx. 3 kW
<b>Zużycie powietrza w procesie palenia/ Air consumption during burning</b>	- ok. 2,75m <sup>3</sup> / godzinę (ok. 5,5m <sup>3</sup> / 1l spalania Biopłynu)/ approx. 2,75m <sup>3</sup> /h (approx. 5,5m <sup>3</sup> / 1l bio- fluid)

<b>Pojemność nawilżacza/ Moisturizer capacity</b>	- 0,4l
---	--------

<b>Waga/ Weight</b>	- 53 kg
---------------------	---------

### Komplet zawiera/ Set includes:

- biokominek/ biofireplace
- rączka uniwersalna/ universal handle
- 1l płynu Biopalix/ 1l of Biopalix
- pojemnik ułatwiający wlewanie biopłynu do palnika/ container to fill the burner

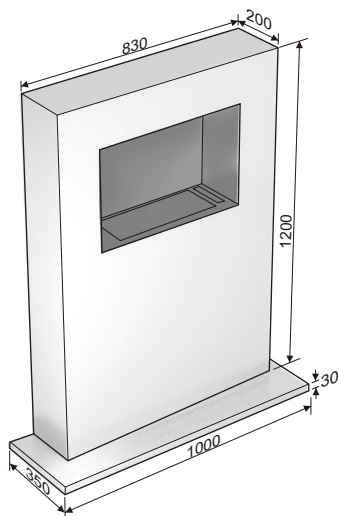

## GRAND

Biokominek z nawilżaczem/ Biofireplace with air-moisturizing

<b>Pojemność palnika/ Burner capacity</b>	- 1,5l
<b>Czas spalania/ Burning time</b>	- 1l biopłynu przy maksymalnym otwarciu zasuw -ok. 2 godz./ 1 litre of fluid lasts for about 2 hours with a fully opened schuter
<b>Moc/ Power</b>	- ok. 3 kW/ approx. 3 kW
<b>Zużycie powietrza w procesie palenia/ Air consumption during burning</b>	- ok. 2,75m <sup>3</sup> / godzinę (ok. 5,5m <sup>3</sup> / 1l spalania Biopłynu)/ approx. 2,75m <sup>3</sup> /h (approx. 5,5m <sup>3</sup> / 1l bio- fluid)

<b>Pojemność nawilżacza/ Moisturizer capacity</b>	- 0,4l
---	--------

<b>Waga/ Weight</b>	- 51 kg
---------------------	---------

### Komplet zawiera/ Set includes:

- biokominek/ biofireplace
- rączka uniwersalna/ universal handle
- 1l płynu Biopalix/ 1l of Biopalix
- pojemnik ułatwiający wlewanie biopłynu do palnika/ container to fill the burner

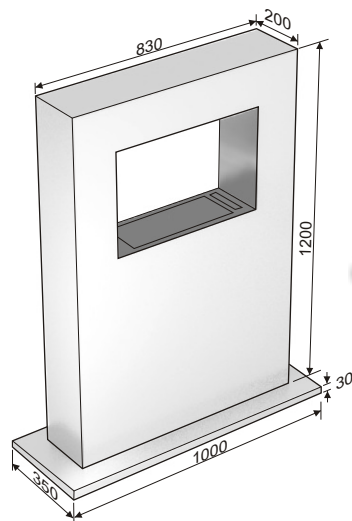



# TORINO

Biokominek z nawilżaczem/ Biofireplace with air-moisturizing

Pojemność palnika/ Burner capacity	- 1,5l
Czas spalania/ Burning time	- 1l biopłynu przy maksymalnym otwarciu zasuw -ok. 2 godz./ 1 litre of fluid lasts for about 2 hours with a fully opened schuter
Moc/ Power	- ok. 3 kW/ approx. 3 kW
Zużycie powietrza w procesie palenia/ Air consumption during burning	- ok. 2,75m <sup>3</sup> / godzinę (ok. 5,5m <sup>3</sup> / 1l spalania Biopłynu)/ approx. 2,75m <sup>3</sup> /h (approx. 5,5m <sup>3</sup> / 1l bio- fluid)

Pojemność nawilżacza/ Moisturizer capacity	- 0,4l
Waga/ Weight	- 27 kg

### Komplet zawiera/ Set includes:

- biokominek/ biofireplace
- rączka uniwersalna/ universal handle
- 1l płynu Biopalix/ 1l of Biopalix
- pojemnik ułatwiający wlewanie biopłynu do palnika/ container to fill the burner

### Wersje/ versions:

- bez podstawy/ without base
- z podstawą/ with base

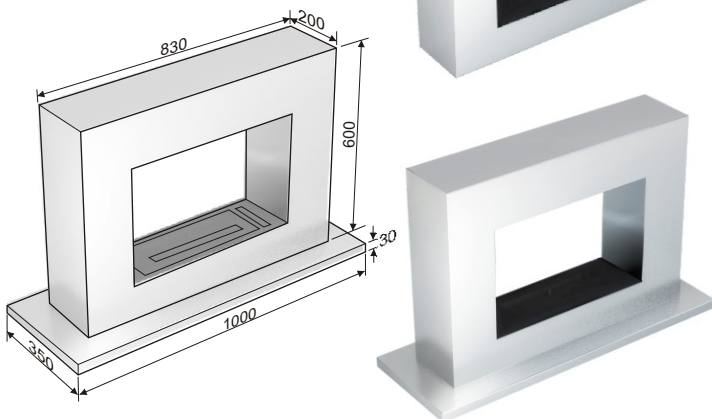

# RADON

Biokominek z nawilżaczem/ Biofireplace with air-moisturizing

Pojemność palnika/ Burner capacity	- 1,5l
Czas spalania/ Burning time	- 1l biopłynu przy maksymalnym otwarciu zasuw -ok. 2 godz./ 1 litre of fluid lasts for about 2 hours with a fully opened schuter
Moc/ Power	- ok. 3 kW/ approx. 3 kW
Zużycie powietrza w procesie palenia/ Air consumption during burning	- ok. 2,75m <sup>3</sup> / godzinę (ok. 5,5m <sup>3</sup> / 1l spalania Biopłynu)/ approx. 2,75m <sup>3</sup> /h (approx. 5,5m <sup>3</sup> / 1l bio- fluid)

Pojemność nawilżacza/ Moisturizer capacity	- 0,4l
Waga/ Weight	- 26 kg

### Komplet zawiera/ Set includes:

- biokominek/ biofireplace
- rączka uniwersalna/ universal handle
- 1l płynu Biopalix/ 1l of Biopalix
- pojemnik ułatwiający wlewanie biopłynu do palnika/ container to fill the burner

### Wersje/ versions:

- bez podstawy/ without base
- z podstawą/ with base

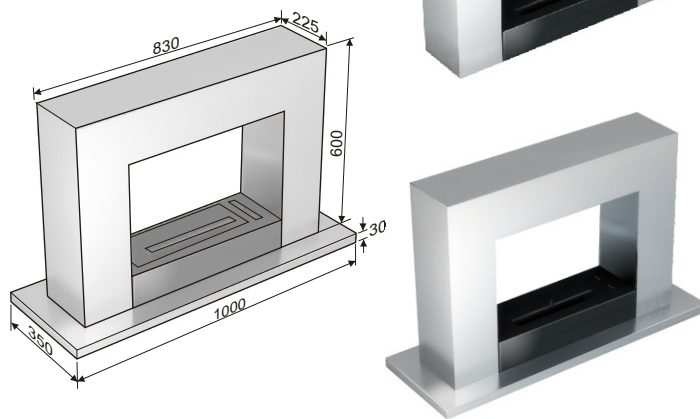



## FARO

Biokominek z nawilżaczem/ Biofireplace with air-moisturizing

<b>Pojemność palnika/ Burner capacity</b>	- 1l
<b>Czas spalania/ Burning time</b>	- 1l biopłynu przy maksymalnym otwarciu zasuw -ok. 4,5 godz./ 1 litre of fluid lasts for about 4,5 hours with a fully opened schuter
<b>Moc/ Power</b>	- ok. 1,5 kW/ approx. 1,5 kW
<b>Zużycie powietrza w procesie palenia/ Air consumption during burning</b>	- ok. 1,3m <sup>3</sup> / godzinę (ok. 5,5m <sup>3</sup> / 1l spalania Biopłynu)/ approx. 1,3m <sup>3</sup> /h (approx. 5,5m <sup>3</sup> / 1l bio- fluid)

<b>Pojemność nawilżacza/ Moisturizer capacity</b>	- 1l
<b>Waga/ Weight</b>	- 20 kg

### Komplet zawiera/ Set includes:

- biokominek/ biofireplace
- rączka uniwersalna/ universal handle
- 1l płynu Biopalix/ 1l of Biopalix
- pojemnik ułatwiający wlewanie biopłynu do palnika/ container to fill the burner
- zestaw montażowy/ montage set

U. Pat. W117282

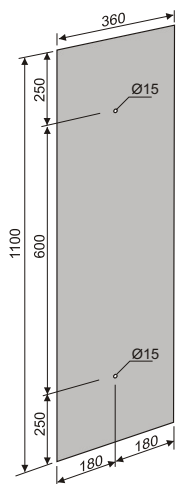
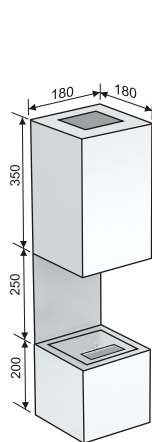

szkło hartowane gr. 6 mm (malowane)  
painted toughened glass 6mm



## FOCUS

Biokominek z nawilżaczem/ Biofireplace with air-moisturizing

<b>Pojemność palnika/ Burner capacity</b>	- 1l
<b>Czas spalania/ Burning time</b>	- 1l biopłynu przy maksymalnym otwarciu zasuw -ok. 4,5 godz./ 1 litre of fluid lasts for about 4,5 hours with a fully opened schuter
<b>Moc/ Power</b>	- ok. 1,5 kW/ approx. 1,5 kW
<b>Zużycie powietrza w procesie palenia/ Air consumption during burning</b>	- ok. 1,3m <sup>3</sup> / godzinę (ok. 5,5m <sup>3</sup> / 1l spalania Biopłynu)/ approx. 1,3m <sup>3</sup> /h (approx. 5,5m <sup>3</sup> / 1l bio- fluid)

<b>Pojemność nawilżacza/ Moisturizer capacity</b>	- 1l
<b>Waga/ Weight</b>	- 26 kg

### Komplet zawiera/ Set includes:

- biokominek/ biofireplace
- rączka uniwersalna/ universal handle
- 1l płynu Biopalix/ 1l of Biopalix
- pojemnik ułatwiający wlewanie biopłynu do palnika/ container to fill the burner
- zestaw montażowy/ montage set

U. Pat. W117282

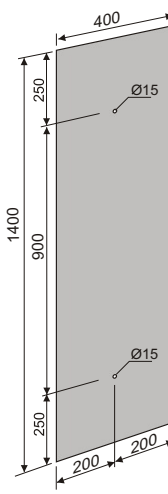
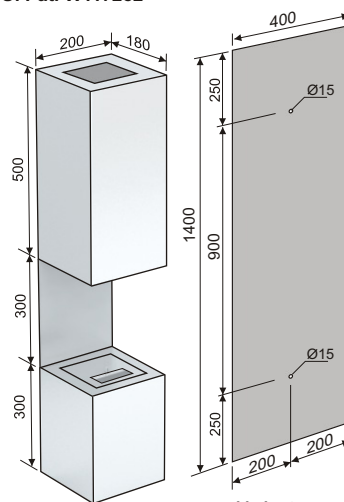

szkło hartowane gr. 6 mm (malowane)  
painted toughened glass 6mm





# LUXOR

Biokominek z nawilżaczem/ Biofireplace with air-moisturizing

<b>Pojemność palnika/ Burner capacity</b>	- 1,5l
<b>Czas spalania/ Burning time</b>	- 1l biopłynu przy maksymalnym otwarciu zasuw -ok. 2 godz./ 1 litre of fluid lasts for about 2 hours with a fully opened schuter
<b>Moc/ Power</b>	- ok. 3 kW/ approx. 3 kW
<b>Zużycie powietrza w procesie palenia/ Air consumption during burning</b>	- ok. 2,75m <sup>3</sup> / godzinę (ok. 5,5m <sup>3</sup> / 1l spalania Biopłynu)/ approx. 2,75m <sup>3</sup> /h (approx. 5,5m <sup>3</sup> / 1l bio- fluid)

<b>Pojemność nawilżacza/ Moisturizer capacity</b>	- 0,4l
---	--------

<b>Waga/ Weight</b>	- 25 kg
---------------------	---------

### Komplet zawiera/ Set includes:

- biokominek/ biofireplace
- rączka uniwersalna/ universal handle
- 1l płynu Biopalix/ 1l of Biopalix
- pojemnik ułatwiający wlewanie biopłynu do palnika/ container to fill the burner
- zestaw montażowy/ montage set

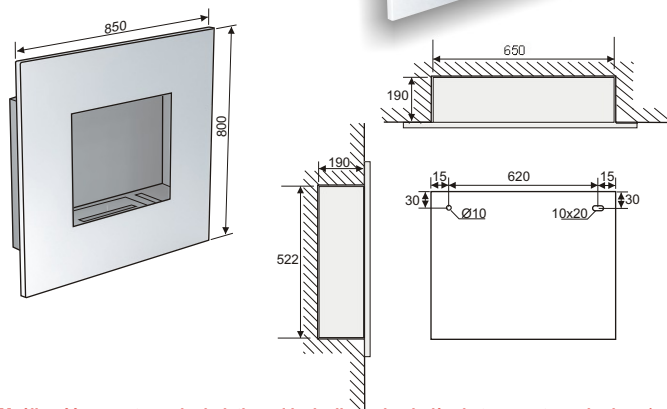

# IMPERIAL

Biokominek z nawilżaczem/ Biofireplace with air-moisturizing

<b>Pojemność palnika/ Burner capacity</b>	- 1,5l
<b>Czas spalania/ Burning time</b>	- 1l biopłynu przy maksymalnym otwarciu zasuw -ok. 2 godz./ 1 litre of fluid lasts for about 2 hours with a fully opened schuter
<b>Moc/ Power</b>	- ok. 3 kW/ approx. 3 kW
<b>Zużycie powietrza w procesie palenia/ Air consumption during burning</b>	- ok. 2,75m <sup>3</sup> / godzinę (ok. 5,5m <sup>3</sup> / 1l spalania Biopłynu)/ approx. 2,75m <sup>3</sup> /h (approx. 5,5m <sup>3</sup> / 1l bio- fluid)

<b>Pojemność nawilżacza/ Moisturizer capacity</b>	- 0,4l
---	--------

<b>Waga/ Weight</b>	- 26 kg
---------------------	---------

### Komplet zawiera/ Set includes:

- biokominek/ biofireplace
- rączka uniwersalna/ universal handle
- 1l płynu Biopalix/ 1l of Biopalix
- pojemnik ułatwiający wlewanie biopłynu do palnika/ container to fill the burner
- zestaw montażowy/ montage set



### U. Pat. W117515

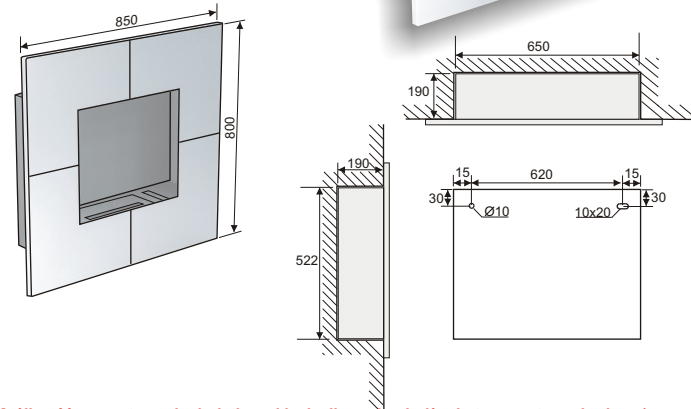

Możliwość zamontowania dodatkowej izolacji w celu obniżenia temperatury obudowy/

14 Possibility of mounting the additional isolation for lowering the temperature of the casing.

Możliwość zamontowania dodatkowej izolacji w celu obniżenia temperatury obudowy/

Possibility of mounting the additional isolation for lowering the temperature of the casing.15



## CARO

Biokominek z nawilżaczem/ Biofireplace with air-moisturizing

<b>Pojemność palnika/ Burner capacity</b>	- 2,5l
<b>Czas spalania/ Burning time</b>	- 1l biopłynu przy maksymalnym otwarciu zasuw -ok. 1,5 godz./ 1 litre of fluid lasts for about 1,5 hours with a fully opened schuter
<b>Moc/ Power</b>	- ok. 3,7 kW/ approx. 3,7 kW
<b>Zużycie powietrza w procesie palenia/ Air consumption during burning</b>	- ok. 3,6m <sup>3</sup> / godzinę (ok. 5,5m <sup>3</sup> / 1l spalania Biopłynu)/ approx. 3,6m <sup>3</sup> /h (approx. 5,5m <sup>3</sup> / 1l bio- fluid)

<b>Pojemność nawilżacza/ Moisturizer capacity</b>	- 0,4l
---	--------

<b>Waga/ Weight</b>	- 23 kg
---------------------	---------

### Komplet zawiera/ Set includes:

- biokominek/ biofireplace
- rączka uniwersalna/ universal handle
- 1l płynu Biopalix/ 1l of Biopalix
- pojemnik ułatwiający wlewanie biopłynu do palnika/ container to fill the burner
- zestaw montażowy/ montage set



U. Pat. W117515

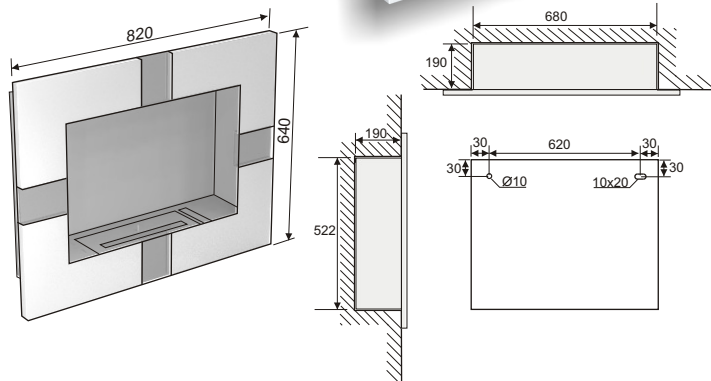

Możliwość zamontowania dodatkowej izolacji w celu obniżenia temperatury obudowy/ Possibility of mounting the additional isolation for lowering the temperature of the casing.16



## MILANO

Biokominek z nawilżaczem/ Biofireplace with air-moisturizing

<b>Pojemność palnika/ Burner capacity</b>	- 2,5l
<b>Czas spalania/ Burning time</b>	- 1l biopłynu przy maksymalnym otwarciu zasuw -ok. 1,5 godz./ 1 litre of fluid lasts for about 1,5 hours with a fully opened schuter
<b>Moc/ Power</b>	- ok. 3,7 kW/ approx. 3,7 kW
<b>Zużycie powietrza w procesie palenia/ Air consumption during burning</b>	- ok. 3,6m <sup>3</sup> / godzinę (ok. 5,5m <sup>3</sup> / 1l spalania Biopłynu)/ approx. 3,6m <sup>3</sup> /h (approx. 5,5m <sup>3</sup> / 1l bio- fluid)

<b>Pojemność nawilżacza/ Moisturizer capacity</b>	- 0,4l
---	--------

<b>Waga/ Weight</b>	- 22 kg
---------------------	---------

### Komplet zawiera/ Set includes:

- biokominek/ biofireplace
- rączka uniwersalna/ universal handle
- 1l płynu Biopalix/ 1l of Biopalix
- pojemnik ułatwiający wlewanie biopłynu do palnika/ container to fill the burner
- zestaw montażowy/ montage set



U. Pat. W117515

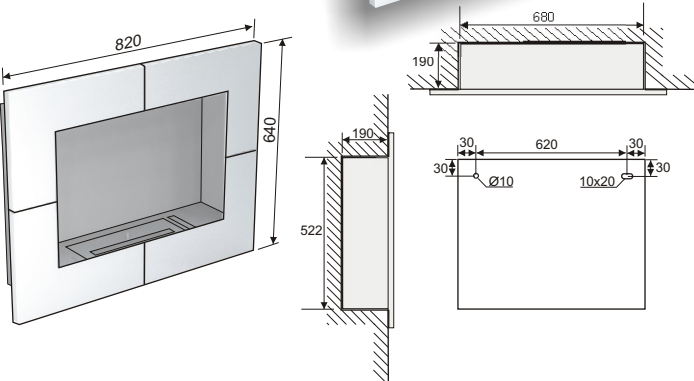

Możliwość zamontowania dodatkowej izolacji w celu obniżenia temperatury obudowy/ Possibility of mounting the additional isolation for lowering the temperature of the casing.17



# ARIZONA

Biokominek z nawilżaczem/ Biofireplace with air-moisturizing

<b>Pojemność palnika/ Burner capacity</b>	- 2,5l
<b>Czas spalania/ Burning time</b>	- 1l biopłynu przy maksymalnym otwarciu zasuw -ok. 1,5 godz./ 1 litre of fluid lasts for about 1,5 hours with a fully opened schuter
<b>Moc/ Power</b>	- ok. 3,7 kW/ approx. 3,7 kW
<b>Zużycie powietrza w procesie palenia/ Air consumption during burning</b>	- ok. 3,6m <sup>3</sup> / godzinę (ok. 5,5m <sup>3</sup> / 1l spalania Biopłynu)/ approx. 3,6m <sup>3</sup> /h (approx. 5,5m <sup>3</sup> / 1l bio- fluid)

<b>Pojemność nawilżacza/ Moisturizer capacity</b>	- 0,4l
---	--------

<b>Waga/ Weight</b>	- ze szkłem/ with glass -24 kg	- z piaskowcem/ with sandstone -30 kg
---------------------	--------------------------------	---------------------------------------

### Komplet zawiera/ Set includes:

- biokominek/ biofireplace
- rączka uniwersalna/ universal handle
- 1l płynu Biopalix/ 1l of Biopalix
- pojemnik ułatwiający wlewanie biopłynu do palnika/ container to fill the burner
- zestaw montażowy/ montage set

U. Pat. W117517

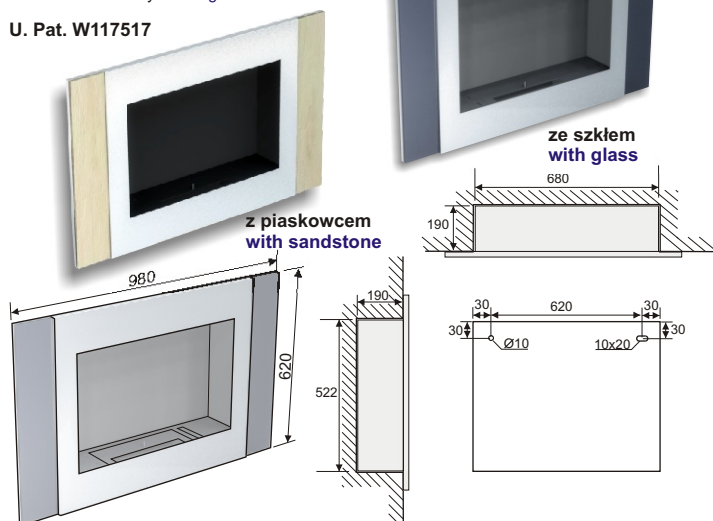

# ARKADIA

Biokominek z nawilżaczem/ Biofireplace with air-moisturizing

<b>Pojemność palnika/ Burner capacity</b>	- 2,5l
<b>Czas spalania/ Burning time</b>	- 1l biopłynu przy maksymalnym otwarciu zasuw -ok. 1,5 godz./ 1 litre of fluid lasts for about 1,5 hours with a fully opened schuter
<b>Moc/ Power</b>	- ok. 3,7 kW/ approx. 3,7 kW
<b>Zużycie powietrza w procesie palenia/ Air consumption during burning</b>	- ok. 3,6m <sup>3</sup> / godzinę (ok. 5,5m <sup>3</sup> / 1l spalania Biopłynu)/ approx. 3,6m <sup>3</sup> /h (approx. 5,5m <sup>3</sup> / 1l bio- fluid)

<b>Pojemność nawilżacza/ Moisturizer capacity</b>	- 0,4l
---	--------

<b>Waga/ Weight</b>	- ze szkłem/ with glass -25 kg	- z piaskowcem/ with sandstone -31 kg
---------------------	--------------------------------	---------------------------------------

### Komplet zawiera/ Set includes:

- biokominek/ biofireplace
- rączka uniwersalna/ universal handle
- 1l płynu Biopalix/ 1l of Biopalix
- pojemnik ułatwiający wlewanie biopłynu do palnika/ container to fill the burner
- zestaw montażowy/ montage set

U. Pat. W117516

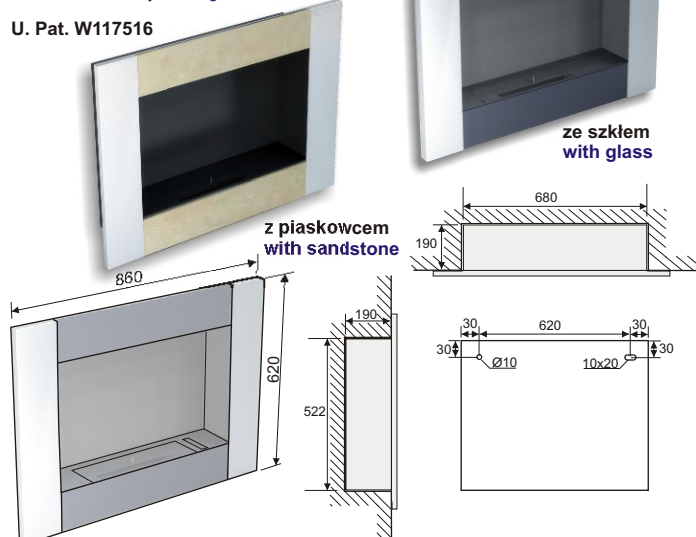



## PLAZA

Biokominek z nawilżaczem/ Biofireplace with air-moisturizing

Pojemność palnika/ Burner capacity	- 2,5l
Czas spalania/ Burning time	- 1l biopłynu przy maksymalnym otwarciu zasuwki -ok. 1,5 godz./ 1 litre of fluid lasts for about 1,5 hours with a fully opened schuter
Moc/ Power	- ok. 3,7 kW/ approx. 3,7 kW
Zużycie powietrza w procesie palenia/ Air consumption during burning	- ok. 3,6m <sup>3</sup> / godzinę (ok. 5,5m <sup>3</sup> / 1l spalania Biopłynu)/ approx. 3,6m <sup>3</sup> /h (approx. 5,5m <sup>3</sup> / 1l bio- fluid)
Pojemność nawilżacza/ Moisturizer capacity	- 0,4l
Waga/ Weight	- 22 kg

### Komplet zawiera/ Set includes:

- biokominek/ biofireplace
- rączka uniwersalna/ universal handle
- 1l płynu Biopalix/ 1l of Biopalix
- pojemnik ułatwiający wlewanie biopłynu do palnika/ container to fill the burner
- zestaw montażowy/ montage set

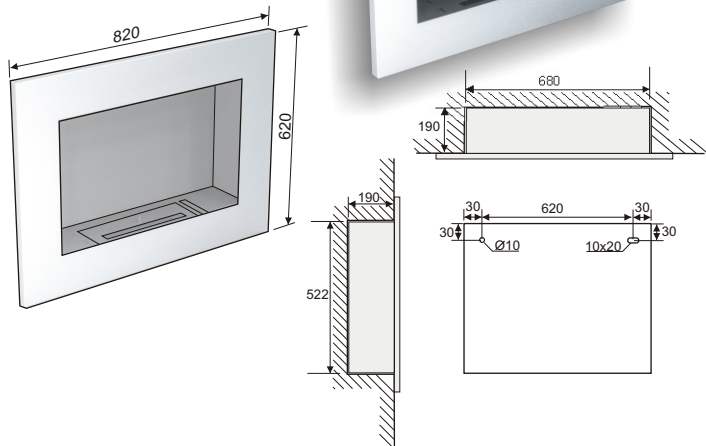

## NOGI

do biokominków/ Legs for biofireplaces

### NOGA 600mm/ LEG 600mm

#### Wersje wykończenia/ version of the timing:

- piaskowiec/ sandstone
- łupek/ slate
- szlif/ cut

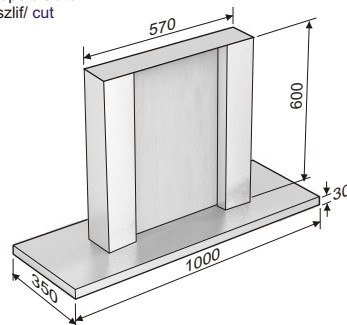

#### Nogi do modeli/ Legs for models:

LUXOR, IMPERIAL, CARO, MILANO, ARIZONA, ARKADIA, PLAZA, PANAMA

### NOGA 400mm/ LEG 400mm

#### Wersje wykończenia/ version of the timing:

- piaskowiec/ sandstone
- łupek/ slate
- szlif/ cut

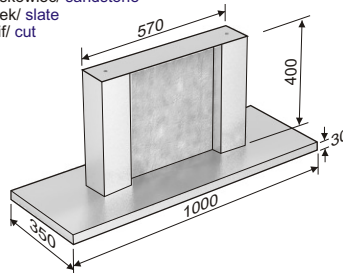

#### Nogi do modeli/ Legs for models:

LUXOR, IMPERIAL, CARO, MILANO, ARIZONA, ARKADIA, PLAZA, PANAMA



# PANAMA

Biokominek z nawilżaczem/ Biofireplace with air-moisturizing

<b>Pojemność palnika/ Burner capacity</b>	- 1,5l
<b>Czas spalania/ Burning time</b>	- 1l biopłynu przy maksymalnym otwarciu zasuw -ok. 2 godz./ 1 litre of fluid lasts for about 2 hours with a fully opened schuter
<b>Moc/ Power</b>	- ok. 3 kW/ approx. 3 kW
<b>Zużycie powietrza w procesie palenia/ Air consumption during burning</b>	- ok. 2,75m <sup>3</sup> / godzinę (ok. 5,5m <sup>3</sup> / 1l spalania Biopłynu)/ approx. 2,75m <sup>3</sup> /h (approx. 5,5m <sup>3</sup> / 1l bio- fluid)

<b>Pojemność nawilżacza/ Moisturizer capacity</b>	- 1,5l
<b>Waga/ Weight</b>	- 21 kg

**Komplet zawiera/ Set includes:**

- biokominek/ biofireplace
- rączka uniwersalna/ universal handle
- 1l płynu Biopalix/ 1l of Biopalix
- pojemnik ułatwiający wlewanie biopłynu do palnika/ container to fill the burner
- zestaw montażowy/ montage set

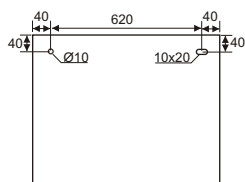

U. Pat. W117264

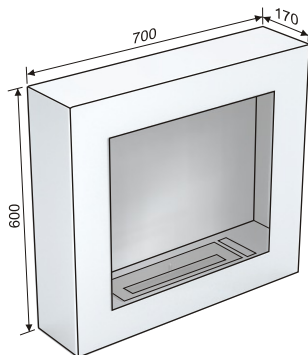

# CALIFORNIA

Biokominek z nawilżaczem/ Biofireplace with air-moisturizing

<b>Pojemność palnika/ Burner capacity</b>	- 1,5l
<b>Czas spalania/ Burning time</b>	- 1l biopłynu przy maksymalnym otwarciu zasuw -ok. 2 godz./ 1 litre of fluid lasts for about 2 hours with a fully opened schuter
<b>Moc/ Power</b>	- ok. 3 kW/ approx. 3 kW
<b>Zużycie powietrza w procesie palenia/ Air consumption during burning</b>	- ok. 2,75m <sup>3</sup> / godzinę (ok. 5,5m <sup>3</sup> / 1l spalania Biopłynu)/ approx. 2,75m <sup>3</sup> /h (approx. 5,5m <sup>3</sup> / 1l bio- fluid)

<b>Pojemność nawilżacza/ Moisturizer capacity</b>	- 2l
<b>Waga/ Weight</b>	- 21 kg

**Komplet zawiera/ Set includes:**

- biokominek/ biofireplace
- rączka uniwersalna/ universal handle
- 1l płynu Biopalix/ 1l of Biopalix
- pojemnik ułatwiający wlewanie biopłynu do palnika/ container to fill the burner
- zestaw montażowy/ montage set

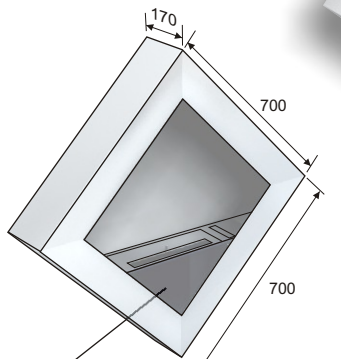

szkło hartowane gr. 6 mm (malowane)  
painted toughened glass 6mm

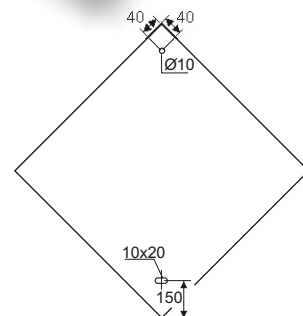



# TOLEDO

**Pojemność palnika/ Burner capacity**  
**Czas spalania/ Burning time**

- 1,2l
- 1l biopłynu przy maksymalnym otwarciu zasuw -ok. 2,5 godz./ 1 litre of fluid lasts for about 2,5 hours with a fully opened schuter
- ok. 2,3 kW/ approx. 2,3 kW
- ok. 2,2m<sup>3</sup>/ godzinę (ok. 5,5m<sup>3</sup>/ 1l spalania Biopłynu)/ approx. 2,2m<sup>3</sup>/h (approx. 5,5m<sup>3</sup>/ 1l bio- fluid)

**Moc/ Power**  
**Zużycie powietrza w procesie palenia/ Air consumption during burning**

**Wersje wykończenia/ versions of the trimming**

- aluminium
- stal nierdzewna szlifowana/ cut stainless steel

**Waga/ Weight**

- 26 kg

**Komplet zawiera/ Set includes:**

- biokominek/ biofireplace
- rączka uniwersalna/ universal handle
- 1l płynu Biopalix/ 1l of Biopalix
- pojemnik ułatwiający wlewanie biopłynu do palnika/ container to fill the burner
- zestaw montażowy/ montage set

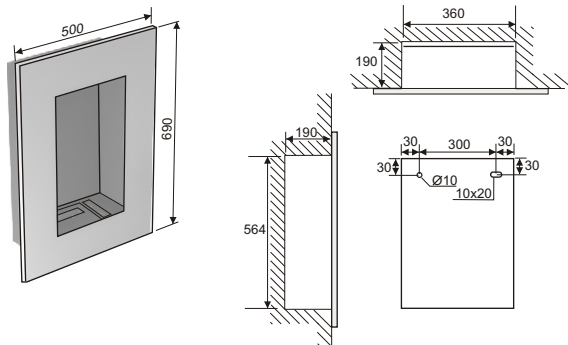

# ORION

**Pojemność palnika/ Burner capacity**  
**Czas spalania/ Burning time**

- 1,5l
- 1l biopłynu przy maksymalnym otwarciu zasuw -ok. 2 godz./ 1 litre of fluid lasts for about 2 hours with a fully opened schuter
- ok. 3 kW/ approx. 3 kW
- ok. 2,75m<sup>3</sup>/ godzinę (ok. 5,5m<sup>3</sup>/ 1l spalania Biopłynu)/ approx. 2,75m<sup>3</sup>/h (approx. 5,5m<sup>3</sup>/ 1l bio- fluid)

**Moc/ Power**  
**Zużycie powietrza w procesie palenia/ Air consumption during burning**

**Wersje wykończenia/ versions of the trimming**

- aluminium
- stal nierdzewna szlifowana/ cut stainless steel

**Waga/ Weight**

- 26 kg

**Komplet zawiera/ Set includes:**

- biokominek/ biofireplace
- rączka uniwersalna/ universal handle
- 1l płynu Biopalix/ 1l of Biopalix
- pojemnik ułatwiający wlewanie biopłynu do palnika/ container to fill the burner
- zestaw montażowy/ montage set

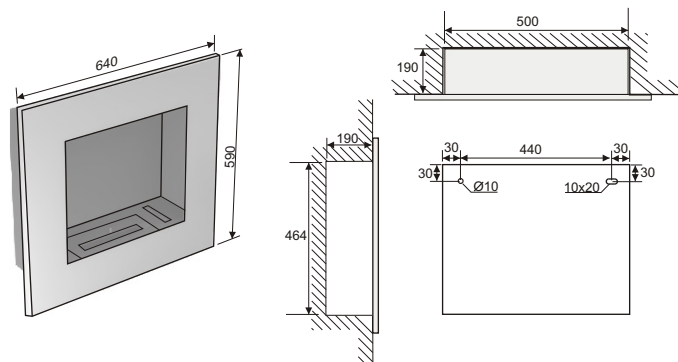
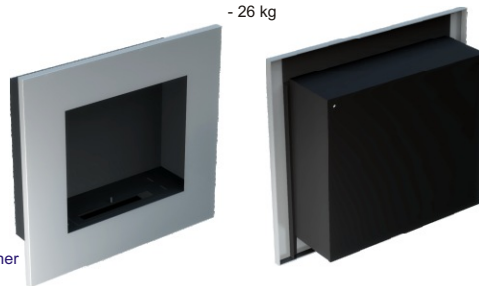

## ROMA

Biokominek z nawilżaczem/ Biofireplace with air-moisturizing

<b>Pojemność palnika/ Burner capacity</b>	- 1,5l
<b>Czas spalania/ Burning time</b>	- 1l biopłynu przy maksymalnym otwarciu zasuw -ok. 2 godz./ 1 litre of fluid lasts for about 2 hours with a fully opened schuter
<b>Moc/ Power</b>	- ok. 3 kW/ approx. 3 kW
<b>Zużycie powietrza w procesie palenia/ Air consumption during burning</b>	- ok. 2,75m <sup>3</sup> / godzinę (ok. 5,5m <sup>3</sup> / 1l spalania Biopłynu)/ approx. 2,75m <sup>3</sup> /h (approx. 5,5m <sup>3</sup> / 1l bio- fluid)

<b>Pojemność nawilżacza/ Moisturizer capacity</b>	- 1l
<b>Waga/ Weight</b>	- 12,5 kg

### Komplet zawiera/ Set includes:

- biokominek/ biofireplace
- rączka uniwersalna/ universal handle
- 1l płynu Biopalix/ 1l of Biopalix
- pojemnik ułatwiający wlewanie biopłynu do palnika/ container to fill the burner
- zestaw montażowy/ montage set

U. Pat. W117081

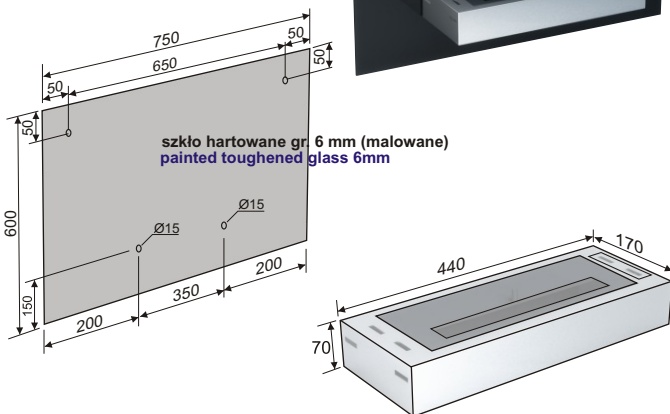

## ROMA 2

Biokominek z nawilżaczem/ Biofireplace with air-moisturizing

<b>Pojemność palnika/ Burner capacity</b>	- 1,5l
<b>Czas spalania/ Burning time</b>	- 1l biopłynu przy maksymalnym otwarciu zasuw -ok. 2 godz./ 1 litre of fluid lasts for about 2 hours with a fully opened schuter
<b>Moc/ Power</b>	- ok. 3 kW/ approx. 3 kW
<b>Zużycie powietrza w procesie palenia/ Air consumption during burning</b>	- ok. 2,75m <sup>3</sup> / godzinę (ok. 5,5m <sup>3</sup> / 1l spalania Biopłynu)/ approx. 2,75m <sup>3</sup> /h (approx. 5,5m <sup>3</sup> / 1l bio- fluid)

<b>Pojemność nawilżacza/ Moisturizer capacity</b>	- 1l
<b>Waga/ Weight</b>	- 15,5 kg

### Komplet zawiera/ Set includes:

- biokominek/ biofireplace
- rączka uniwersalna/ universal handle
- 1l płynu Biopalix/ 1l of Biopalix
- pojemnik ułatwiający wlewanie biopłynu do palnika/ container to fill the burner
- zestaw montażowy/ montage set

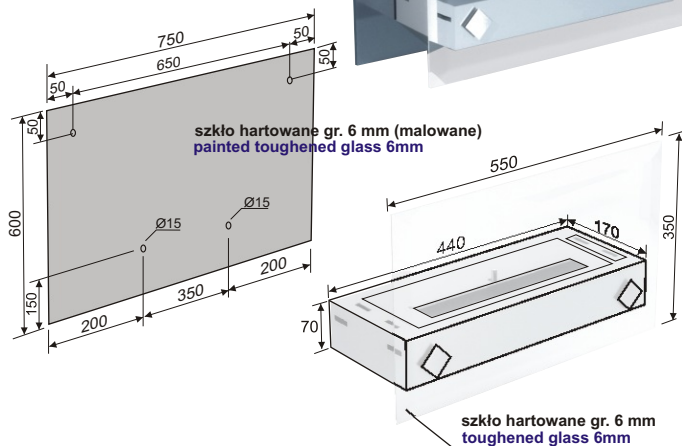



# MONTANA

Biokominiek z nawilżaczem/ Biofireplace with air-moisturizing

<b>Pojemność palnika/ Burner capacity</b>	- 1,5l
<b>Czas spalania/ Burning time</b>	- 1l biopłynu przy maksymalnym otwarciu zasuw -ok. 4,5 godz./ 1 litre of fluid lasts for about 4,5 hours with a fully opened schuter
<b>Moc/ Power</b>	- ok. 1,5 kW/ approx. 1,5 kW
<b>Zużycie powietrza w procesie palenia/ Air consumption during burning</b>	- ok. 1,3m <sup>3</sup> / godzinę (ok. 5,5m <sup>3</sup> / 1l spalania Biopłynu)/ approx. 1,3m <sup>3</sup> /h (approx. 5,5m <sup>3</sup> / 1l bio- fluid)

<b>Pojemność nawilżacza/ Moisturizer capacity</b>	- 0,7l
---	--------

<b>Waga/ Weight</b>	- 7,5 kg
---------------------	----------

### Komplet zawiera/ Set includes:

- biokominiek/ biofireplace
- rączka uniwersalna/ universal handle
- 1l płynu Biopalix/ 1l of Biopalix
- pojemnik ułatwiający wlewanie biopłynu do palnika/ container to fill the burner
- zestaw montażowy/ montage set

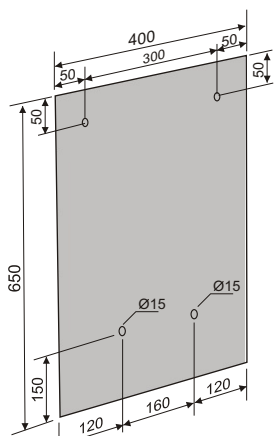

szkło hartowane gr. 6 mm (malowane)  
painted toughened glass 6mm

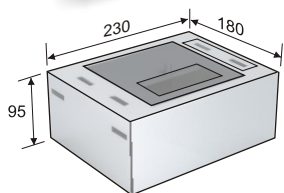

# DRAGON

Biokominiek z nawilżaczem/ Biofireplace with air-moisturizing

<b>Pojemność palnika/ Burner capacity</b>	- 2x 1,5l
<b>Czas spalania/ Burning time</b>	- 2x 1l biopłynu przy maksymalnym otwarciu zasuw -ok. 2 godz./ 2x 1 litre of fluid lasts for about 2 hours with a fully opened schuter
<b>Moc/ Power</b>	- ok. 6 kW/ approx. 6 kW
<b>Zużycie powietrza w procesie palenia/ Air consumption during burning</b>	- ok. 5,5m <sup>3</sup> / godzinę (ok. 5,5m <sup>3</sup> / 1l spalania Biopłynu)/ approx. 5,5m <sup>3</sup> /h (approx. 5,5m <sup>3</sup> / 1l bio- fluid)

<b>Pojemność nawilżacza/ Moisturizer capacity</b>	- 2l
---	------

<b>Waga/ Weight</b>	- 22 kg
---------------------	---------

### Komplet zawiera/ Set includes:

- biokominiek/ biofireplace
- rączka uniwersalna/ universal handle
- 1l płynu Biopalix/ 1l of Biopalix
- pojemnik ułatwiający wlewanie biopłynu do palnika/ container to fill the burner
- zestaw montażowy/ montage set

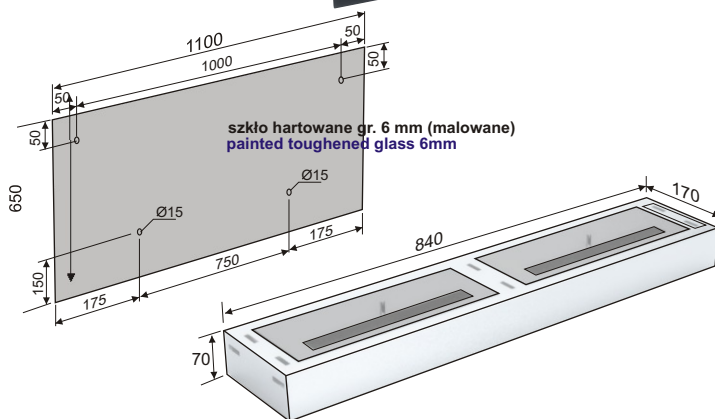
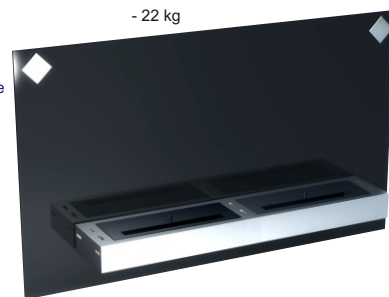

szkło hartowane gr. 6 mm (malowane)  
painted toughened glass 6mm



## ROMA wkład/ inset

Biokominek z nawilżaczem/ Biofireplace with air-moisturizing

<b>Pojemność palnika/ Burner capacity</b>	- 1,5l
<b>Czas spalania/ Burning time</b>	- 1l bioplynu przy maksymalnym otwarciu zasuw -ok. 2 godz./ 1 litre of fluid lasts for about 2 hours with a fully opened schuter
<b>Moc/ Power</b>	- ok. 3 kW/ approx. 3 kW
<b>Zużycie powietrza w procesie palenia/ Air consumption during burning</b>	- ok. 2,75m <sup>3</sup> / godzinę (ok. 5,5m <sup>3</sup> / 1l spalania Bioplynu)/ approx. 2,75m <sup>3</sup> /h (approx. 5,5m <sup>3</sup> / 1l bio- fluid)

<b>Pojemność nawilżacza/ Moisturizer capacity</b>	- 2l
---	------

<b>Waga/ Weight</b>	- 7 kg
---------------------	--------

### Komplet zawiera/ Set includes:

- biokominek/ biofireplace
- rączka uniwersalna/ universal handle
- 1l płynu Biopalix/ 1l of Biopalix
- pojemnik ułatwiający wlewanie bioplynu do palnika/ container to fill the burner

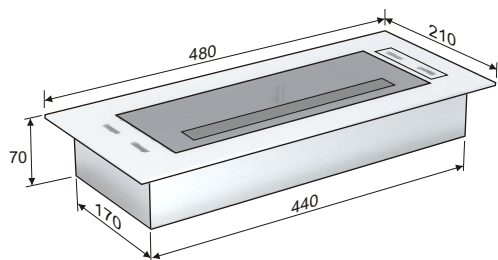

## MONTANA wkład/ inset

Biokominek z nawilżaczem/ Biofireplace with air-moisturizing

<b>Pojemność palnika/ Burner capacity</b>	- 1l
<b>Czas spalania/ Burning time</b>	- 1l bioplynu przy maksymalnym otwarciu zasuw -ok. 4,5 godz./ 1 litre of fluid lasts for about 4,5 hours with a fully opened schuter
<b>Moc/ Power</b>	- ok. 1,5 kW/ approx. 1,5 kW
<b>Zużycie powietrza w procesie palenia/ Air consumption during burning</b>	- ok. 1,3m <sup>3</sup> / godzinę (ok. 5,5m <sup>3</sup> / 1l spalania Bioplynu)/ approx. 1,3m <sup>3</sup> /h (approx. 5,5m <sup>3</sup> / 1l bio- fluid)

<b>Pojemność nawilżacza/ Moisturizer capacity</b>	- 2l
---	------

<b>Waga/ Weight</b>	- 4 kg
---------------------	--------

### Komplet zawiera/ Set includes:

- biokominek/ biofireplace
- rączka uniwersalna/ universal handle
- 1l płynu Biopalix/ 1l of Biopalix
- pojemnik ułatwiający wlewanie bioplynu do palnika/ container to fill the burner

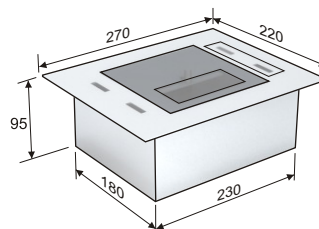



## DRAGON wkład// inset

Biokominek z nawilżaczem/ Biofireplace with air-moisturizing

<b>Pojemność palnika/ Burner capacity</b>	- 2x 1,5l
<b>Czas spalania/ Burning time</b>	- 2x 1l biopłynu przy maksymalnym otwarciu zasuw -ok. 2 godz./ 2x 1 litre of fluid lasts for about 2 hours with a fully opened schuter
<b>Moc/ Power</b>	- ok. 6 kW/ approx. 6 kW
<b>Zużycie powietrza w procesie palenia/ Air consumption during burning</b>	- ok. 5,5m <sup>3</sup> / godzinę (ok. 5,5m <sup>3</sup> / 1l spalania Biopłynu)/ approx. 5,5m <sup>3</sup> /h (approx. 5,5m <sup>3</sup> / 1l bio- fluid)
<b>Pojemność nawilżacza/ Moisturizer capacity</b>	- 2l
<b>Waga/ Weight</b>	- 14 kg

### Komplet zawiera/ Set includes:

- biokominek/ biofireplace
- rączka uniwersalna/ universal handle
- 1l płynu Biopalix/ 1l of Biopalix
- pojemnik ułatwiający wlewanie biopłynu do palnika/ container to fill the burner

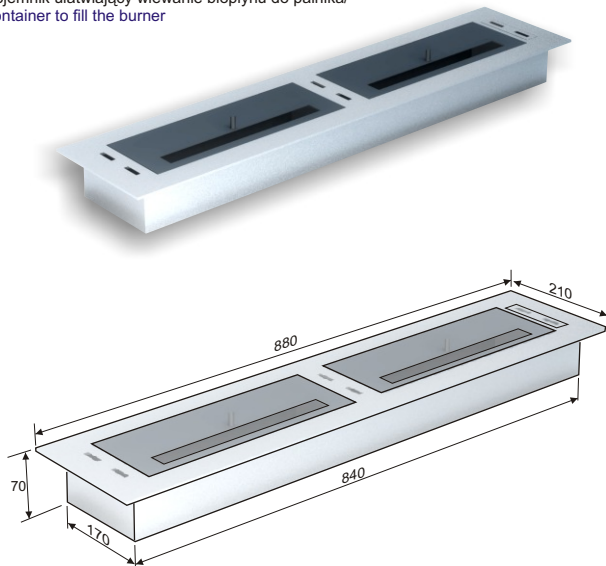

## Wkład skrzynkowy 700/ Plug-in box 700

<b>Pojemność palnika/ Burner capacity</b>	- 2,6l
<b>Czas spalania/ Burning time</b>	- 1l biopłynu przy maksymalnym otwarciu zasuw -ok. 1,5 godz./ 1 litre of fluid lasts for about 1,5 hours with a fully opened schuter
<b>Moc/ Power</b>	- ok. 4 kW/ approx. 4 kW
<b>Zużycie powietrza w procesie palenia/ Air consumption during burning</b>	- ok. 3,6m <sup>3</sup> / godzinę (ok. 5,5m <sup>3</sup> / 1l spalania Biopłynu)/ approx. 3,6m <sup>3</sup> /h (approx. 5,5m <sup>3</sup> / 1l bio- fluid)
<b>Pojemność nawilżacza/ Moisturizer capacity</b>	- 0,4l
<b>Waga/ Weight</b>	- 26 kg

### Komplet zawiera/ Set includes:

- biokominek/ biofireplace
- rączka uniwersalna/ universal handle
- 1l płynu Biopalix/ 1l of Biopalix
- pojemnik ułatwiający wlewanie biopłynu do palnika/ container to fill the burner
- zestaw montażowy/ montage set

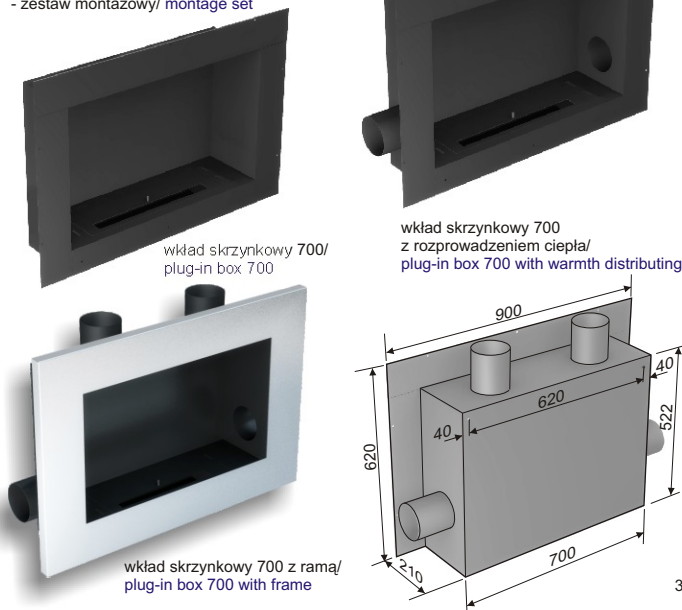



kamienie ozdobne ogniotwale/fireproof decorative stones :  
 - czarne/ black  
 - białe/ white



drwa ozdobne ogniotwale/fireproof decorative firewood:  
 - brzoza/ white birch  
 - dąb/ oak

## AKCESORIA/ACCESSORIES



BIOPALIX<sup>®</sup> - poj. 1L



BIOPALIX<sup>®</sup> - poj. 5L (neutralny)



BIOPALIX<sup>®</sup> - poj. 5L  
 (zapach leśny/ forest smell)



BIOPALIX<sup>®</sup> - poj. 5L  
 (zapach aloes/aloetic smell)



zapalarka/ lighter

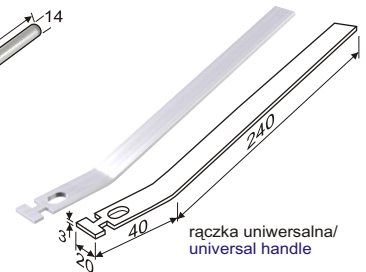

rączka uniwersalna/  
 universal handle



rączka uniwersalna przedłużona/  
 long universal handle



pojemnik ułatwiający wlewanie  
 biopłynu do palnika/  
 container to fill the burner



płyn do czyszczenia stali nierdzewnej  
 stainless steel care spray

# ROZKŁAD TEMPERATUR WOKÓŁ BIKOMINKÓW (BADANIA PROWADZONO W KOMORZE BEZPRZECIĄGOWEJ)

# HEAT DISTRIBUTION AROUND BIO CHIMNEYS (SUPPORTED BY EXPERIMENTAL STUDIES)

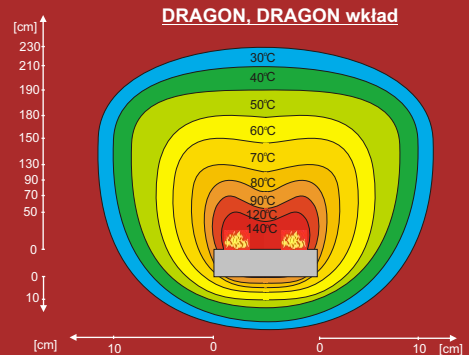
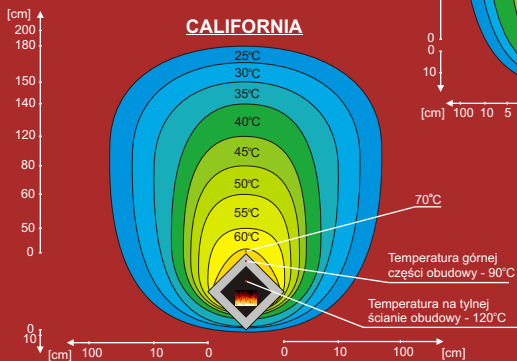
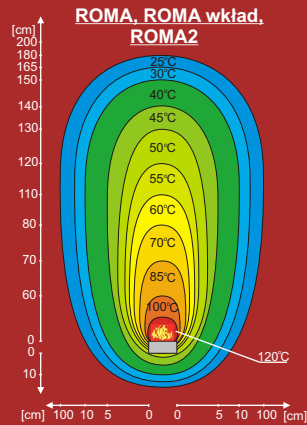
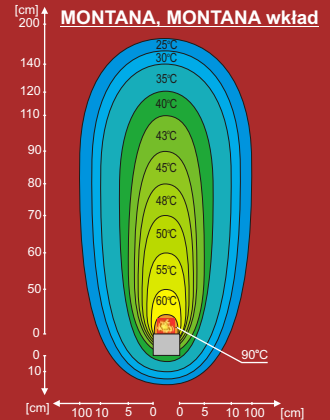
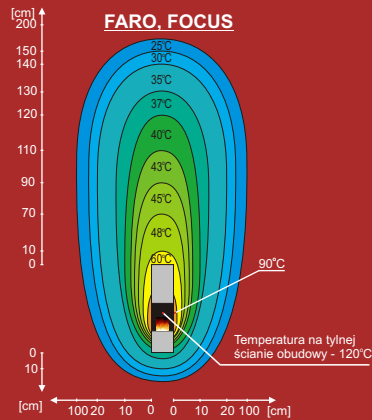
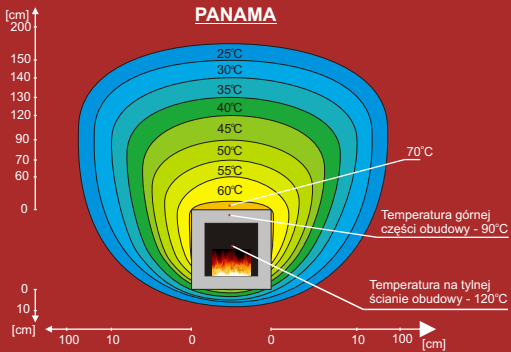
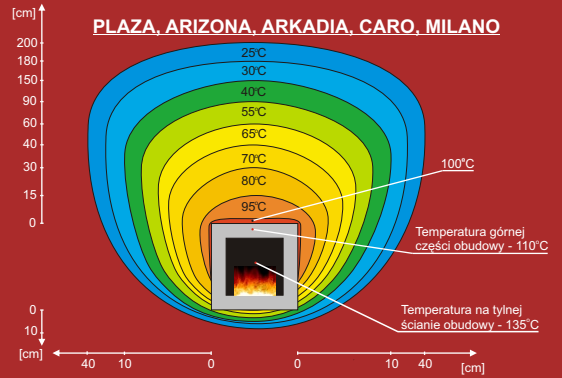
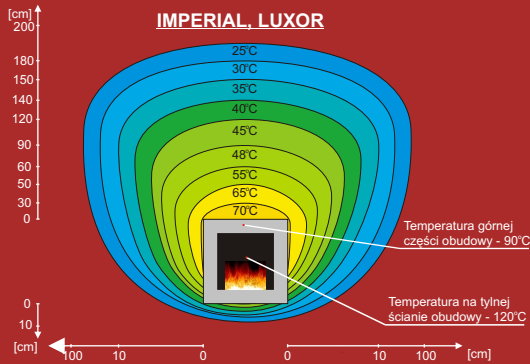



# STARS

STARS to oprawa przeznaczona do podświetlania klatek schodowych, korytarzy, cokołów, ścian oraz tam gdzie pożądane jest oświetlenie dekoracyjne. Dzięki połączeniu prostych materiałów takich jak aluminium i szkło uzyskano unikalne i jedyne w swoim rodzaju efekty świetlne i estetyczne (projekt Jaco Design). Zastosowane jako źródła światła diody LED pobierają znikomą ilość energii elektrycznej (0,48W – 4 LED oraz 0,24W – 3 LED). Oprawa zasilana jest napięciem 12V pochodzącym z zasilacza LED o wymiarach pozwalających umieścić go w podtynkowej puszcze elektrycznej. Diody LED dają białą, zieloną, czerwoną lub niebieską barwę światła. Kwadratowa podstawa o wymiarach 80x80mm wykonana jest ze szkła (14 kolorów).

Łatwość montażu zapewnia sprężysta blaszka z tyłu korpusu, którą wsuwa się do puszki podtynkowej lub otworu o średnicy Ø60 mm. Oprawę można zamontować bezpośrednio na powierzchniach płaskich tam gdzie możliwe jest zastosowanie taśmy samoprzylepnej.

## Dane techniczne STARS O:

Napięcie zasilania:	12V DC
Moc:	
- wersja „4” diodowa	0,48W
- wersja „2” lub „3” diodowa	0,24W
Źródło światła:	diody LED
Klasa ochronności:	III
Stopień ochrony:	IP20
Wymiary po zainstalowaniu (DxSxW) [mm]:	80x80x15
Montaż na powierzchniach normalnie palnych:	TAK
Montaż na powierzchniach meblowych:	TAK

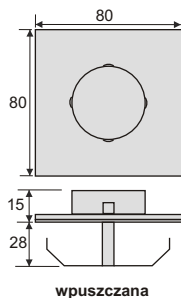
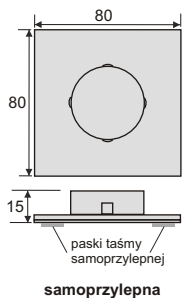

	wpuszczane	samoprzylepne
Nr Art.	STSP/O4/S...	STS/O4/S...
Rodzaj światła	4 szt. LED	
Rodzaj płytki	Kolorowe szkło (14 rodzajów)	

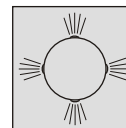

	wpuszczane	samoprzylepne
Nr Art.	STSP/O3Y/S...	STS/O3Y/S...
Rodzaj światła	3 szt. LED	
Rodzaj płytki	Kolorowe szkło (14 rodzajów)	

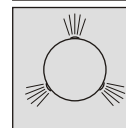

	wpuszczane	samoprzylepne
Nr Art.	STSP/O3T/S...	STS/O3T/S...
Rodzaj światła	3 szt. LED	
Rodzaj płytki	Kolorowe szkło (14 rodzajów)	

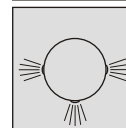

	wpuszczane	samoprzylepne
Nr Art.	STSP/O2V/S...	STS/O2V/S...
Rodzaj światła	2 szt. LED	
Rodzaj płytki	Kolorowe szkło (14 rodzajów)	

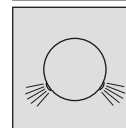

	wpuszczane	samoprzylepne
Nr Art.	STSP/O2/S...	STS/O2/S...
Rodzaj światła	2 szt. LED	
Rodzaj płytki	Kolorowe szkło (14 rodzajów)	

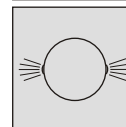

## kolory szkła



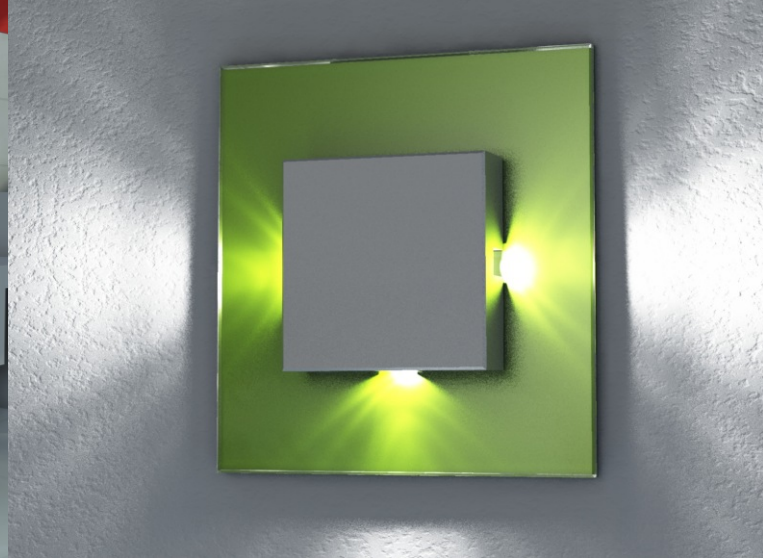

# STARS

STARS to oprawa przeznaczona do podświetlania klatek schodowych, korytarzy, cokołów, ścian oraz tam gdzie pożądane jest oświetlenie dekoracyjne. Dzięki połączeniu prostych materiałów takich jak aluminium i szkło uzyskano unikalne i jedyne w swoim rodzaju efekty świetlne i estetyczne (projekt Jaco Design). Zastosowane jako źródła światła diody LED pobierają znikomą ilość energii elektrycznej (0,48W – 4 LED oraz 0,24W – 3 LED). Oprawa zasilana jest napięciem 12V pochodzącym z zasilacza LED o wymiarach pozwalających umieścić go w podtynkowej puszcze elektrycznej. Diody LED dają białą, zieloną, czerwoną lub niebieską barwę światła. Kwadratowa podstawa o wymiarach 80x80mm wykonana jest ze szkła (14 kolorów).

Łatwość montażu zapewnia sprężysta blaszka z tyłu korpusu, którą wsuwa się do puszki podtynkowej lub otworu o średnicy Ø60 mm. Oprawę można zamontować bezpośrednio na powierzchniach płaskich tam gdzie możliwe jest zastosowanie taśmy samoprzylepnej.

## Dane techniczne STARS K:

Napięcie zasilania:	12V DC
Moc:	
- wersja „4” diodowa	0,48W
- wersja „2” lub „3” diodowa	0,24W
Źródło światła:	diody LED
Klasa ochronności:	III
Stopień ochrony:	IP20
Wymiary po zainstalowaniu (DxSxW) [mm]:	80x80x15
Montaż na powierzchniach normalnie palnych:	TAK
Montaż na powierzchniach meblowych:	TAK

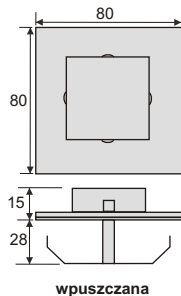
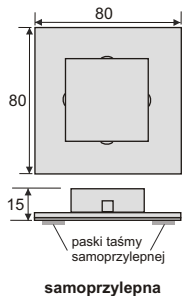

	wpuszczane	samoprzylepne
Nr Art.	STSP/K4/S...	STS/K4/S...
Rodzaj światła	4 szt. LED	
Rodzaj płytki	Kolorowe szkło (14 rodzajów)	

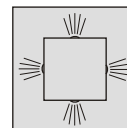

	wpuszczane	samoprzylepne
Nr Art.	STSP/K3T/S...	STS/K3T/S...
Rodzaj światła	3 szt. LED	
Rodzaj płytki	Kolorowe szkło (14 rodzajów)	

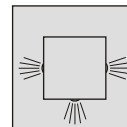

	wpuszczane	samoprzylepne
Nr Art.	STSP/K2V/S...	STS/K2V/S...
Rodzaj światła	2 szt. LED	
Rodzaj płytki	Kolorowe szkło (14 rodzajów)	

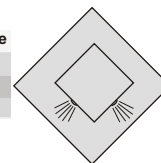

	wpuszczane	samoprzylepne
Nr Art.	STSP/K2/S...	STS/K2/S...
Rodzaj światła	2 szt. LED	
Rodzaj płytki	Kolorowe szkło (14 rodzajów)	

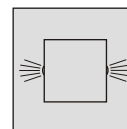

## kolory szkła



# NOTATKI

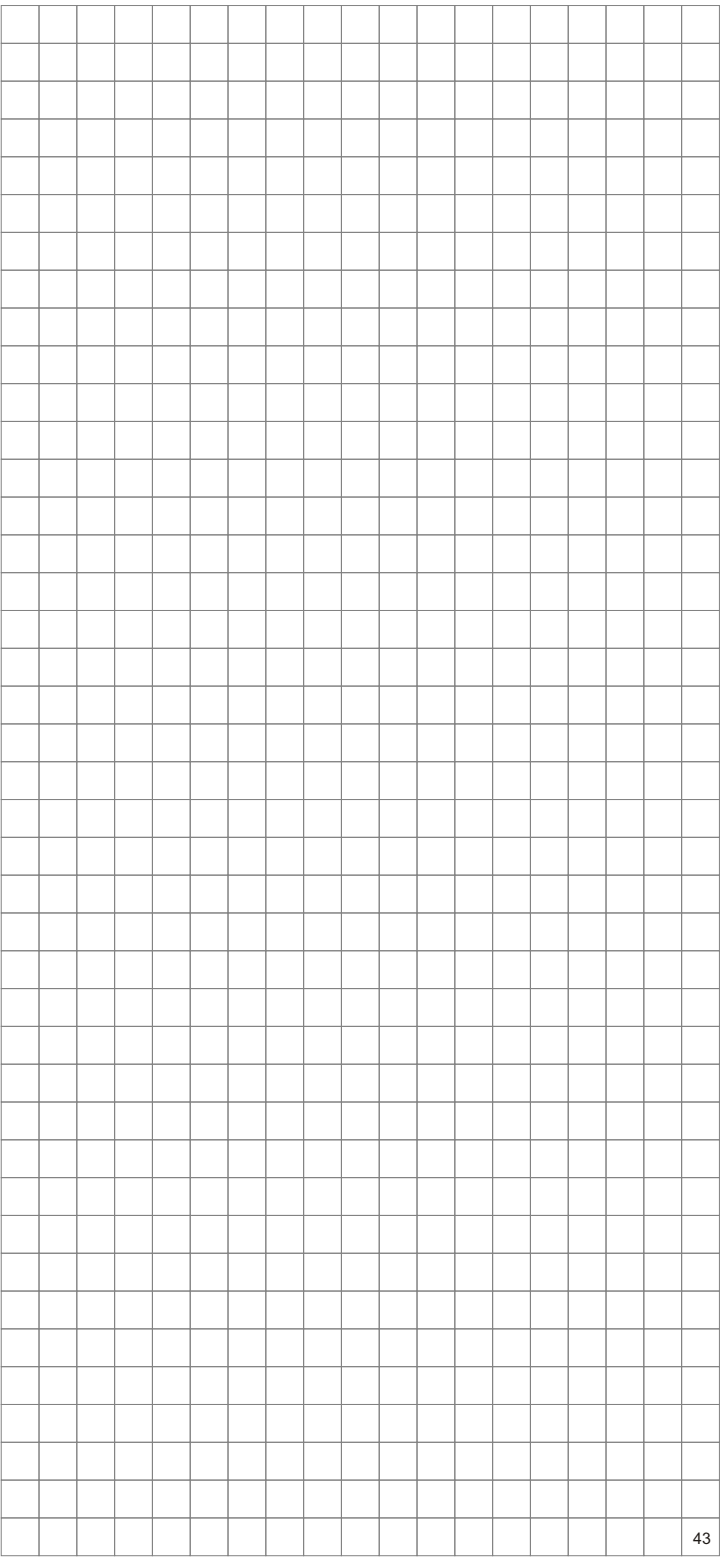
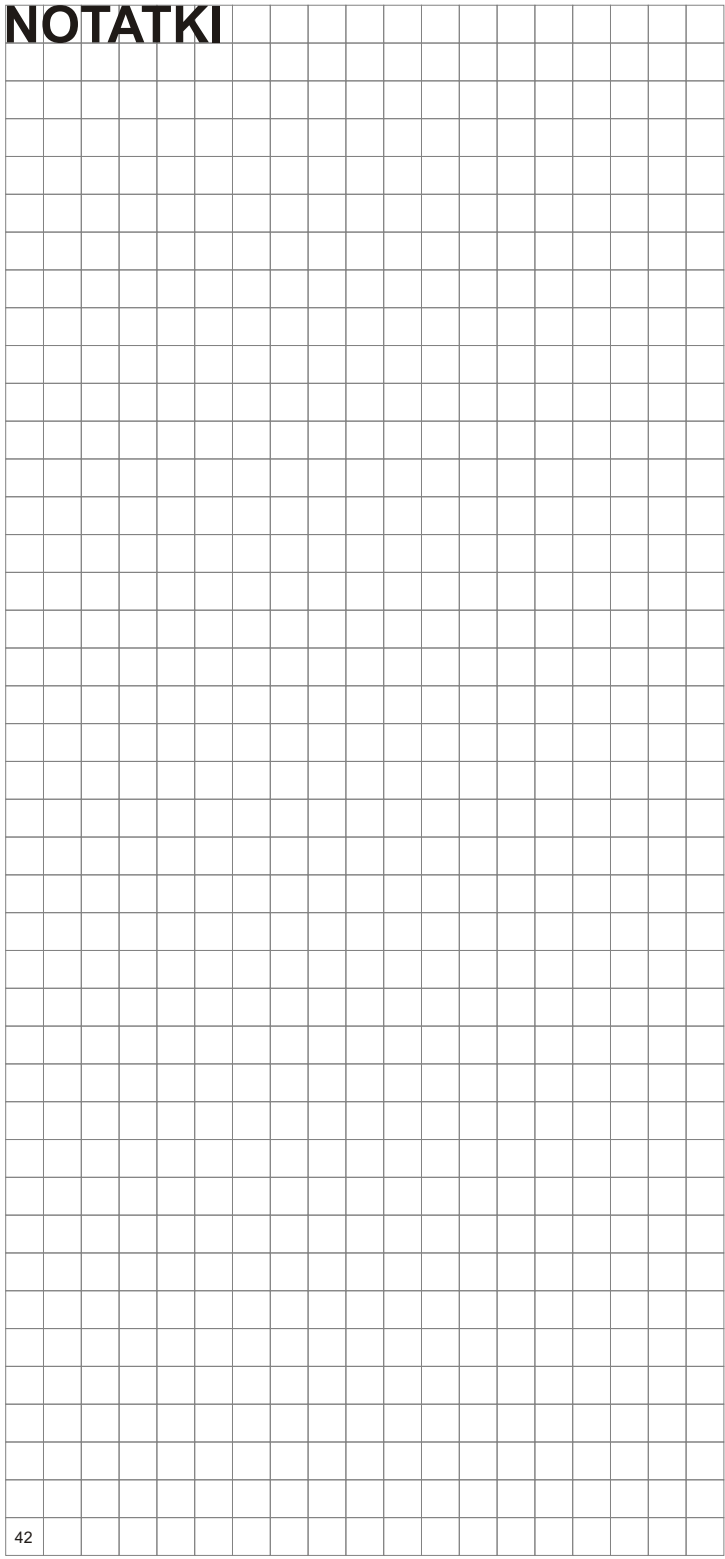

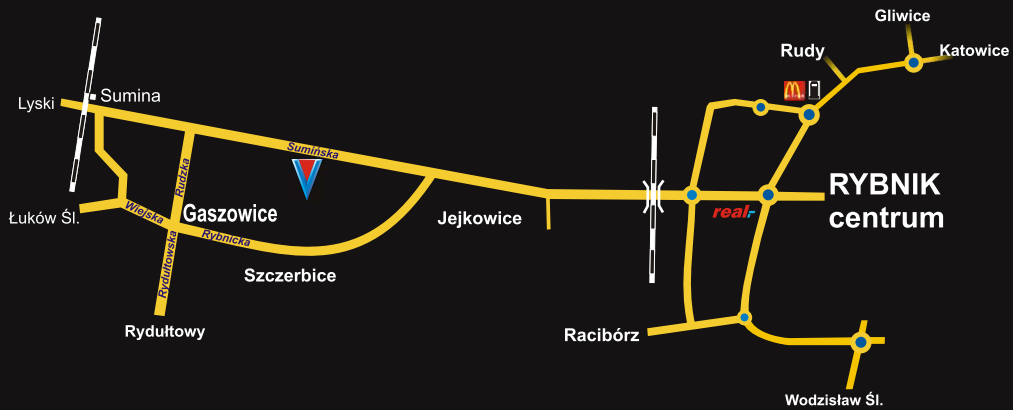

**MCJ: 44-293 Gaszowice ul. Sumińska 2a**  
fax: +48/32/423 92 86  
tel: +48/32/423 45 44  
tel: +48/32/422 92 63  
katalog: [www.mcj.pl](http://www.mcj.pl)  
adres e-mail: [mcj@mcj.pl](mailto:mcj@mcj.pl)

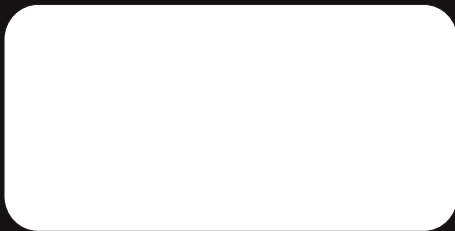



Ogród  
Garden  
Garten



NR	W	💡	G	WYL
OGL01/S/600	600mm	S	—	—
OGL01/S/1100	1100mm	S	—	—
OGL01/S/600/2GW	600mm	S	2	1
OGL01/S/1100/2GW	1100mm	S	2	1
OGL01/L/600	600mm	L	—	—
OGL01/L/1100	1100mm	L	—	—
OGL01/L/600/2GW	600mm	L	2	1
OGL01/L/1100/2GW	1100mm	L	2	1

montaż/assembly/Montage KON/ERD1

230V-50Hz

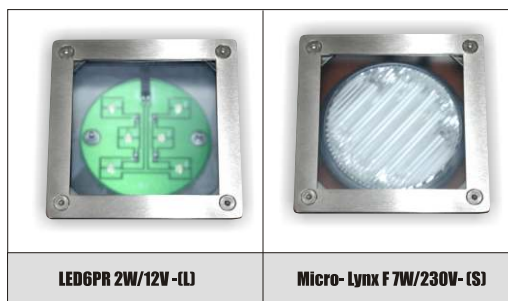
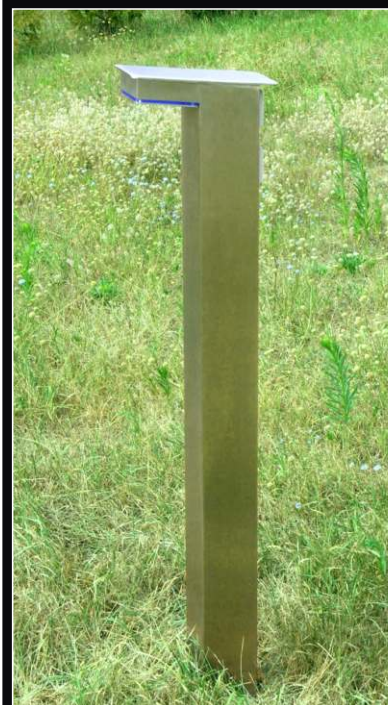
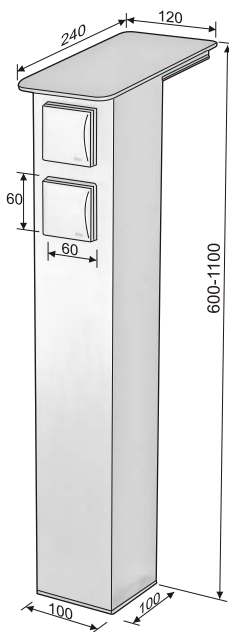

LED6PR 2W/12V- (LI)

Micro- Lynx F 7W/230V- (IS)

NR - nr kat. - cat.Nr. - Art.Nr  
 💡 - żarówka - bulb - Leuchtmittel  
 W - wysokość - height - Höhe  
 G - gniazdko - socket - Steckdose  
 WYL - wyłącznik - switch - Schalter  
 230V-50Hz P<sub>OUT,MAX</sub>=3500W  
 S - Micro-Lynx F 7W/230V  
 L - LED6PR 2W/12V



NR	W	☉	G	WYL
OGL02/S/200	200mm	☉	—	—
OGL02/S/700	700mm	☉	—	—
OGL02/S/1100	1100mm	☉	—	—
OGL02/S/700/GW	700mm	☉	1	1
OGL02/S/1100/GW	1100mm	☉	1	1
OGL02/L/200	200mm	L	—	—
OGL02/L/700	700mm	L	—	—
OGL02/L/1100	1100mm	L	—	—
OGL02/L/700/GW	700mm	L	1	1
OGL02/L/1100/GW	1100mm	L	1	1

montaż/assembly/Montage- KON/ERD1

230V-50Hz IP44 ⚡ CE

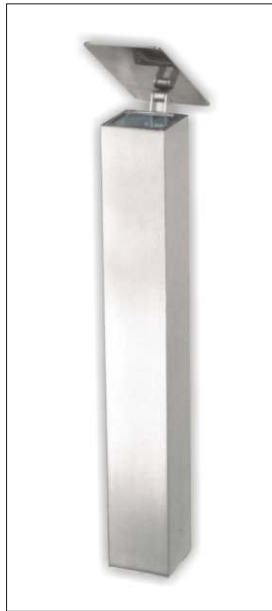
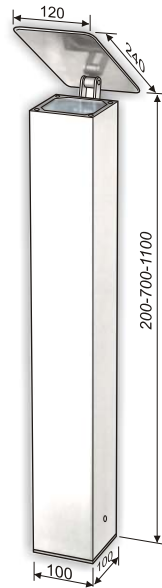

LED6PR 2W/12V-L

Micro-Lynx F 7W/230V-S

- NR - nr kat. • cat. nr • Art. Nr
  - ☉ - żarówka • bulb • Leuchtmittel
  - W - wysokość • height • Höhe
  - G - gniazdko • socket • Steckdose
  - WYL - wyłącznik • switch • Schalter
- 230V-50Hz P<sub>OUT,MAX</sub> = 3500W
- ☉ - Micro-Lynx F 7W/230V
  - L - LED6PR 2W/12V

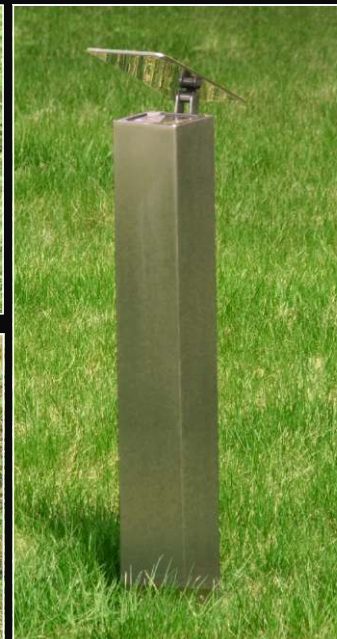



NR	W	💡	G	WYL
OGL03/S/700	700mm	S	—	—
OGL03/S/1100	1100mm	S	—	—
OGL03/L/700	700mm	L	—	—
OGL03/L/1100	1100mm	L	—	—

montaż/assembly/Montage- KON/ERD2

230V-50Hz IP44

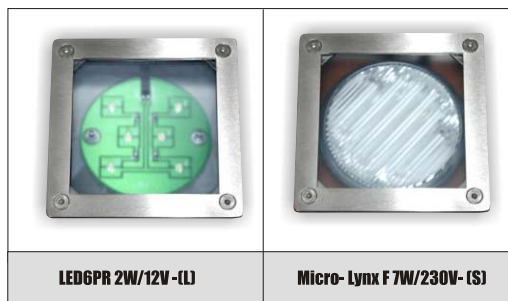
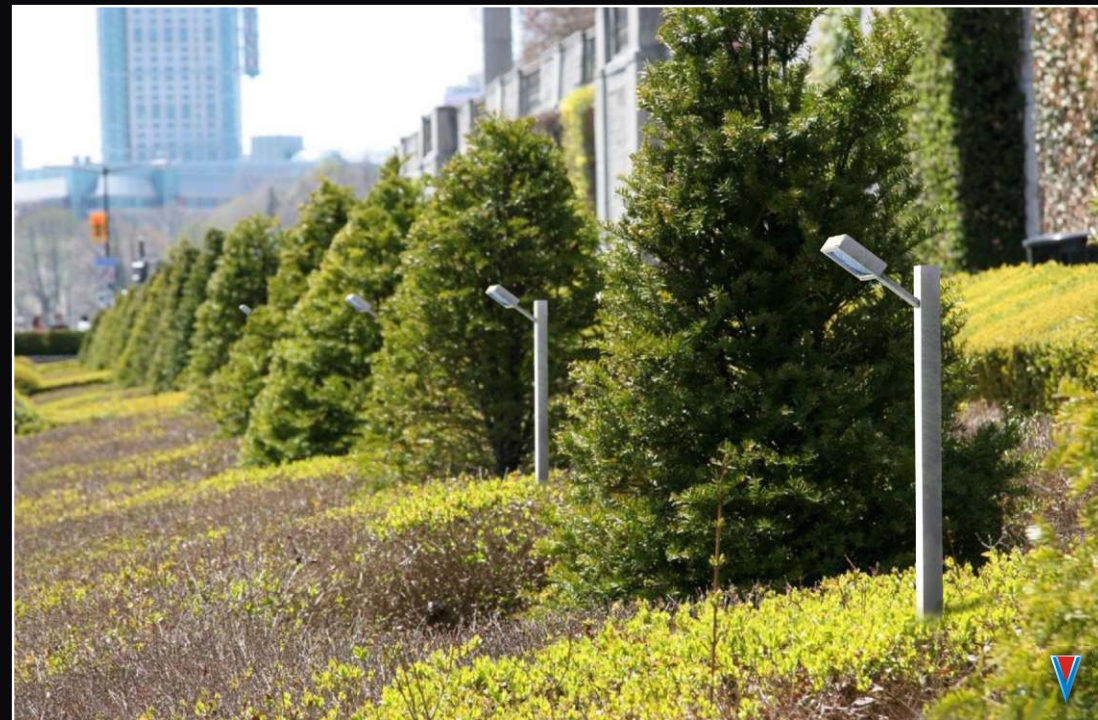
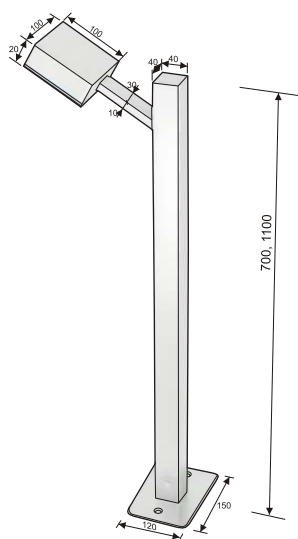

LED6PR 2W/12V - (L)

Micro-Lynx F 7W/230V - (S)

- NR - nr kat. cat. nr - Art. Nr
- 💡 - żarówka - bulb - Leuchtmittel
- W - wysokość - height - Höhe
- S - Micro-Lynx F 7W/230V
- L - LED6PR 2W/12V



NR	W	💡	G	WYL
OGL04/S/700	700mm	S	—	—
OGL04/S/1100	1100mm	S	—	—
OGL04/L/700	700mm	L	—	—
OGL04/L/1100	1100mm	L	—	—

montaż/assembly/Montage- KON/ERD2

230V~50Hz IP44 ⚡ CE

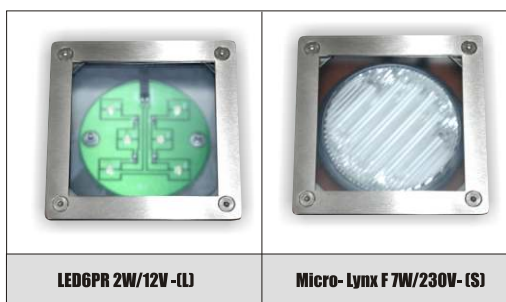
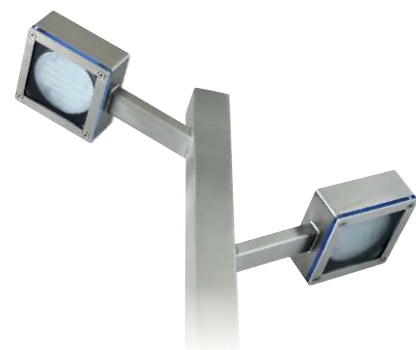
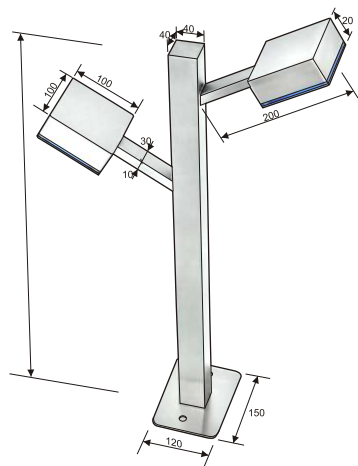

LED6PR 2W/12V -(L)

Micro-Lynx F 7W/230V -(S)

NR - nr kat - cat.nr - Art.Nr  
💡 - żarówka - bulb - Leuchtmittel  
W - wysokość - height - Höhe  
S - Micro-Lynx F 7W/230V  
L - LED6PR 2W/12V

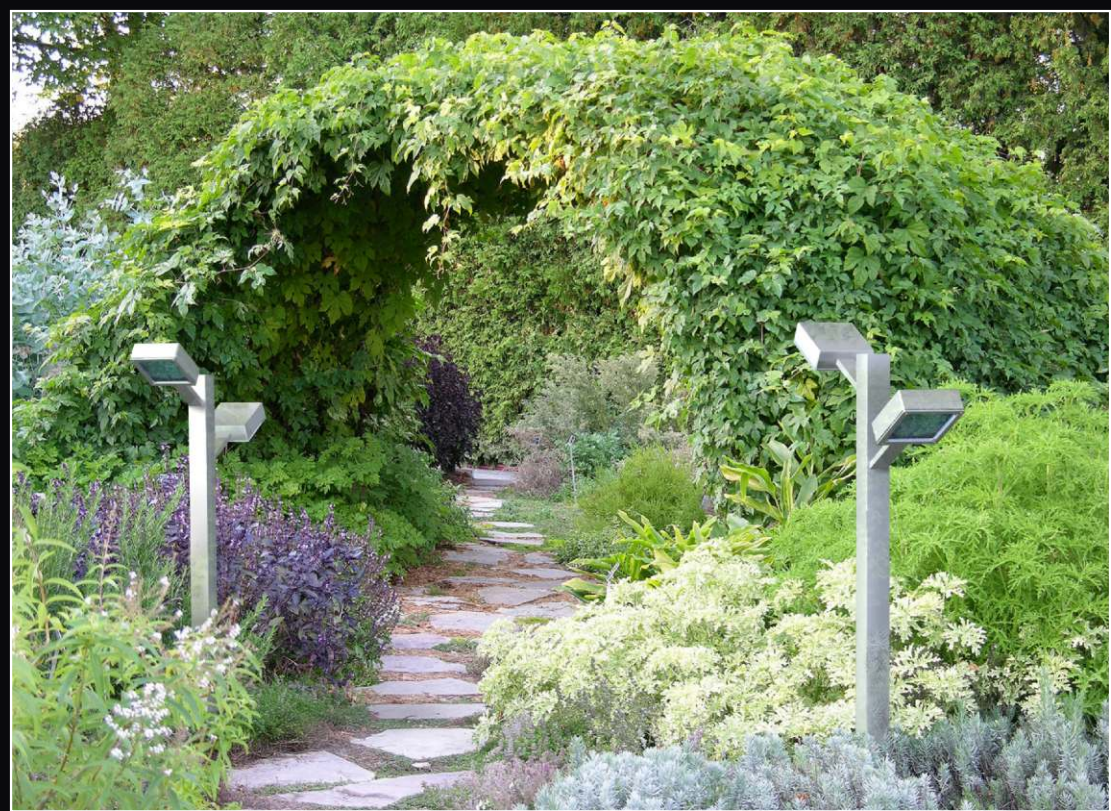



NR	W	☹	G	WYL
OGL05/S/700	700mm	S	—	—
OGL05/S/1100	1100mm	S	—	—
OGL05/L/700	700mm	L	—	—
OGL05/L/1100	1100mm	L	—	—

montaż/assembly/Montage-KON/ERD2

230V-50Hz IP44 ⚡ CE

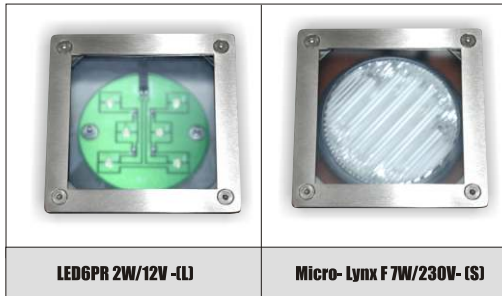
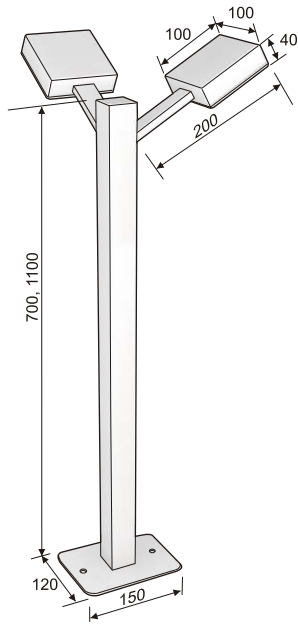

NR - nr kat. cat.nr. Art.Nr  
☹ - żarówka - bulb - Leuchtmittel  
W - wysokość - height - Höhe  
S - Micro-Lynx F 7W/230V  
L - LED6PR 2W/12V



NR	W	💡	G	WYL.
OGL06/S/700	700mm	S	—	—
OGL06/S/1100	1100mm	S	—	—
OGL06/L/700	700mm	L	—	—
OGL06/L/1100	1100mm	L	—	—

montaż/assembly/Montage- KON/ERD2

230V~50Hz IP44  

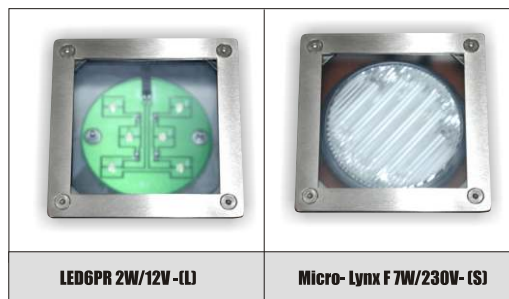
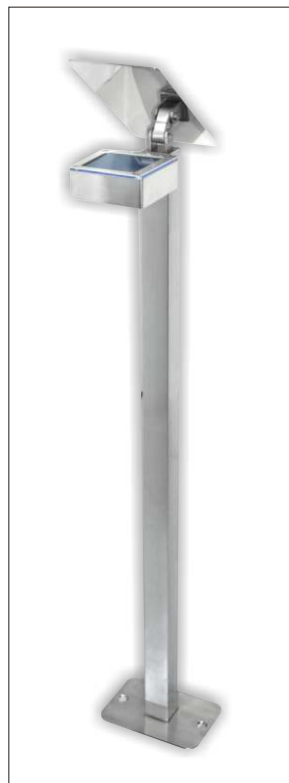
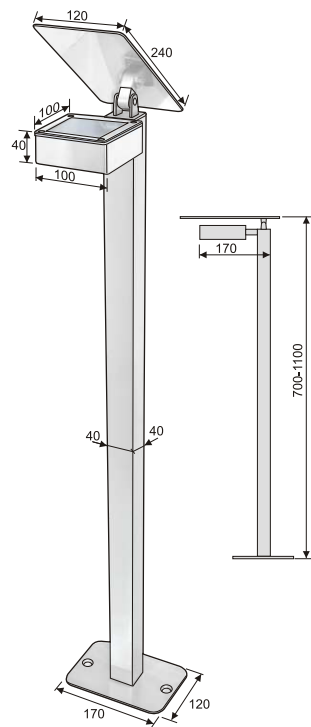

LED6PR 2W/12V (L)

Micro-Lynx F 7W/230V (S)

- NR** - nr kat - cat.nr - Art.Nr
- 💡** - żarówka - bulb - Leuchtmittel
- W** - wysokość - height - Hoehe
- S** - Micro-Lynx F 7W/230V
- L** - LED6PR 2W/12V



NR	G	WYL.
KONG/ST	1	—
KON2G/ST	2	—
KON3G/ST	3	—
KONGW/ST	1	1
KON2GW/ST	2	1

montaż/assembly/Montage- KON/ERD1

230V-50Hz IP44

NR - nr kat. cat. nr. Art. Nr

G - gniazdko - socket - Steckdose

WYL - wyłącznik - switch - Schalter

230V-50Hz P<sub>OUT,MAX</sub> = 3500W

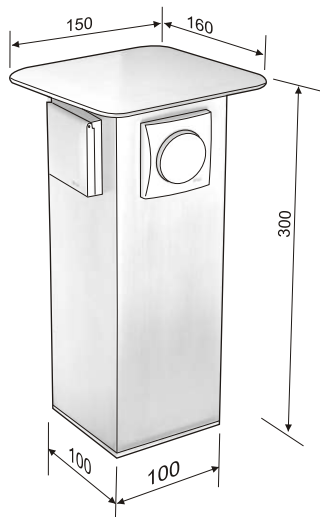

NR	G	GS
KON2GS/ST	2	1
KON3GS/ST	3	1

montaż/assembly/Montage- KON/ERD1

230V-50Hz IP44

NR - nr kat. cat. nr. Art. Nr

G - gniazdko - socket - Steckdose  
230V-50Hz P<sub>OUT,MAX</sub> = 3500W

GS - gniazdko - socket - Steckdose  
3P+N+PE  
230/400V-50Hz  
P<sub>OUT,MAX</sub> = 3500/6000W

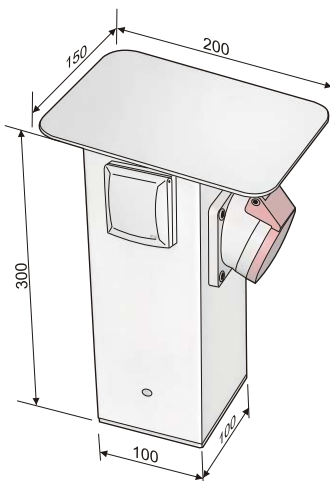



NR	G	WYL	KOLOR
KON2G/CZ	2	—	CZ
KON2G/AL	2	—	AL
KON4G/CZ	4	—	CZ
KON4G/AL	4	—	AL
KON3GW/CZ	3	1	CZ
KON3GW/AL	3	1	AL

montaż/assembly/Montage- KON/ERD2

230V-50Hz IP44  

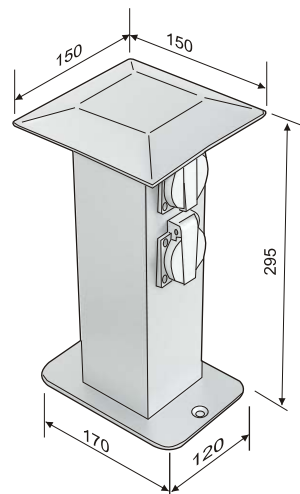

**NR** - nr kat. cat. nr. Art.Nr

**G** - gniazdko socket Steckdose

**WYL** - wyłącznik switch Schalter

230V-50Hz P<sub>OUT,MAX</sub>=3500W

**AL** - aluminium

**CZ** - czarny black Schwarz



**aluminium AL**



**schwarz/black/czarny CZ**

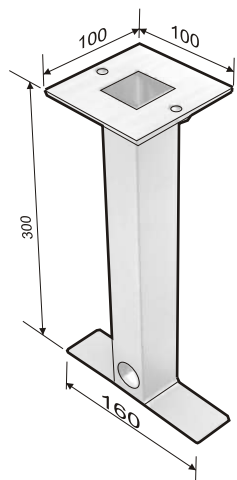

**KON/ERD1**

NIR  
KON/ERD1

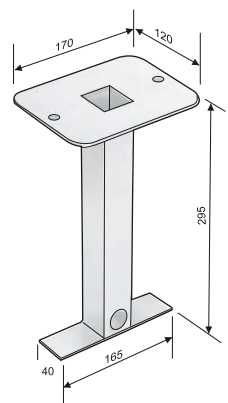
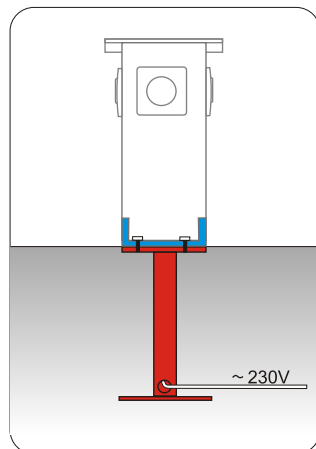

**KON/ERD2**

NIR  
KON/ERD2

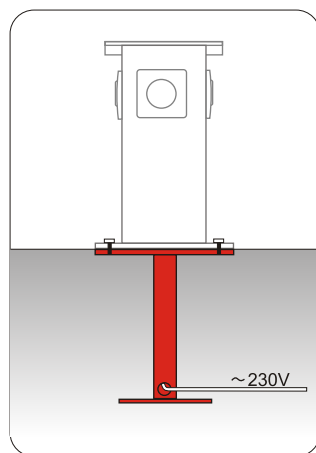

# OMIS

Oprawy ze stali nierdzewnej  
Stainless steel lamps  
Leuchten aus Edelstahl

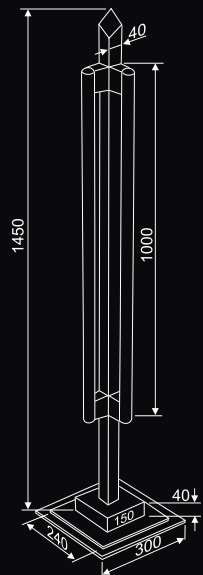

NB	☼	WVK
OMIS-P01-2/WS	S14s max 2x120W	SD

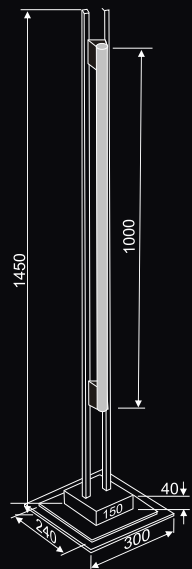

NB	☼	WVK
OMIS-R01-1/WS	S14s max 2x120W	SD



NB - nr kat - cat.nr - Art.Nr  
☼ - żarówka - bulb - Leuchtmittel  
WVK - wykończenie - finishing - Ausfuehrungen

SP - stal polerowana - polishing steel - Stahl poliert  
SD - stal drapana - scratched steel - Stahl gebuerstet

230V-50Hz IP20 CE



# OMI-7S

Oprawy ze stali nierdzewnej  
Stainless steel lamps  
Leuchten aus Edelstahl

## OMI-7S-1

Nr	Żarówka	Wyk.
OMI-7S-1	S	SD

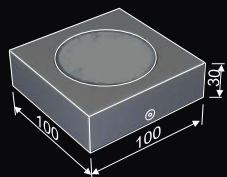

## OMI-7S-2

Nr	Żarówka	Wyk.
OMI-7S-2	S	SD

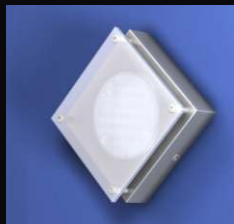
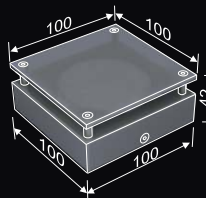

## OMI-7S-3

Nr	Żarówka	Wyk.
OMI-7S-3	S	SD

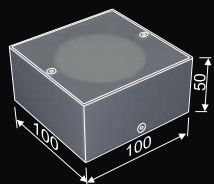

## OMI-7S-3

Nr	Żarówka	Wyk.
OMI-7S-3	S	SD

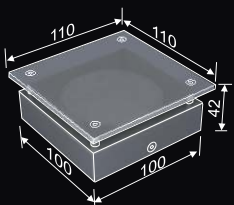

## OMI-7S/Z-2

Nr	Żarówka	Wyk.
OMI-7S/Z-2	S	SD

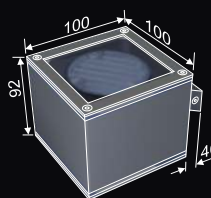

## OMI-7S/Z-1

Nr	Żarówka	Wyk.
OMI-7S/Z-1	S	SD

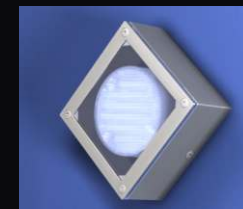
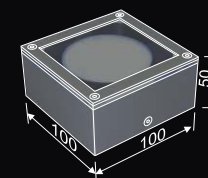

Nr - nr kat. - cat.nr. - Art.Nr  
 Żarówka - bulb - Leuchtmittel  
 S - MICRO-LYNK-F 7W/230V

Wyk. - wykończenie - finishing - Ausfuehrungen  
 SP - stal polerowana - polishing steel - Stahl poliert  
 SD - stal drapana - scratched steel - Stahl gebuerstet

230V - 50Hz



# OMI-006, OMI-008

Oprawy ze stali nierdzewnej  
Stainless steel lamps  
Leuchten aus Edelstahl

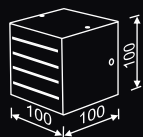
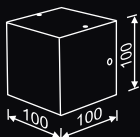

## OMI-006-1G/D

NB	⚡	WVK
OMI-006-1	G9 max 1x40W	SD

KL:  
-B  
-1  
-2  
-3

## OMI-006-2G/D

NB	⚡	WVK
OMI-006-2	G9 max 1x40W	SD

G-góra, D-dół (typ klosza)  
G-up, D-down (type of lampshade)  
G-oben, D-unten (Lampenschirm)  
W zależności od zastosowanego klosza  
można uzyskać różne efekty świetlne.  
Depending of used lampshade  
one can get different light effects.

KL-klosz/ lampshade/ lampenschirm

- B- biały szklany/ white glass/ weiss glas  
1- metal 1 otwór/ metal 1 inlet/ metal 1 Öffnung  
2- metal 2 otwory/ metal 2 inlets/ metal 2 Öffnungen  
3- metal 3 otwory/ metal 3 inlets/ metal 3 Öffnungen

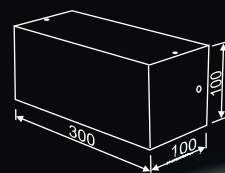
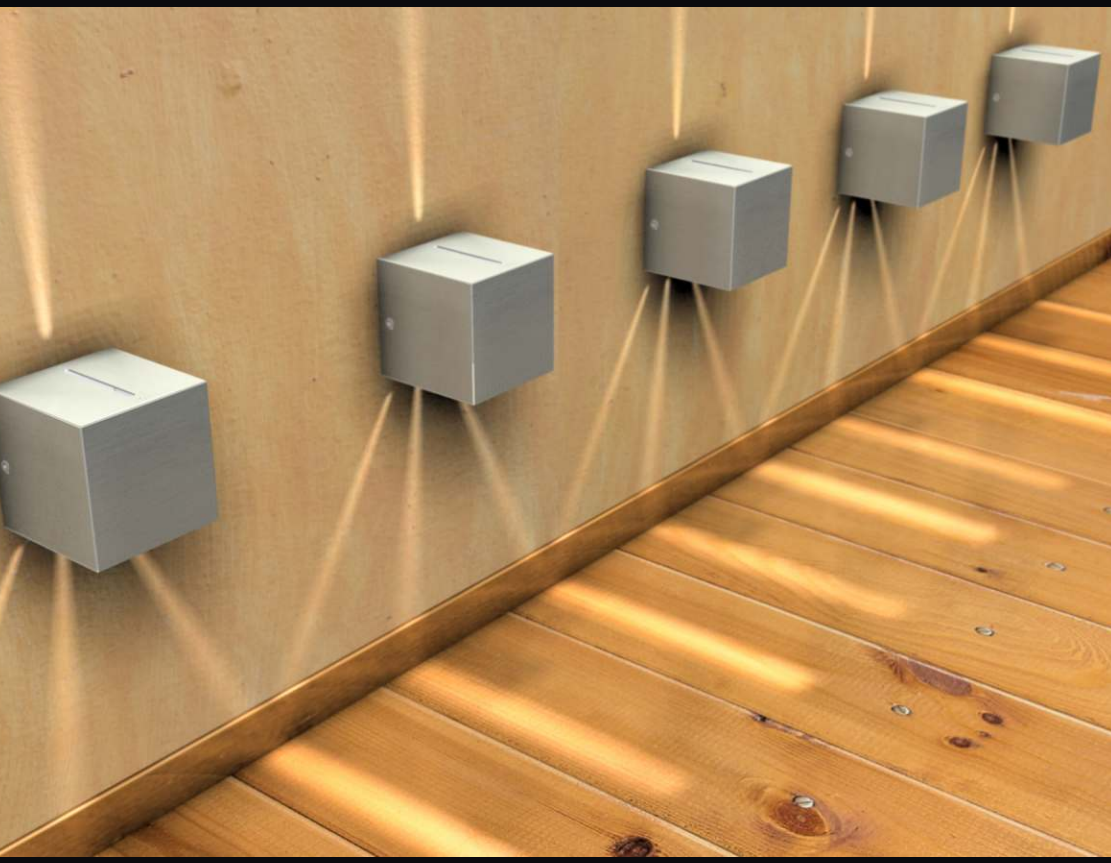
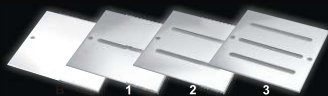

## OMI-008-1B/B

NB	⚡	WVK
OMI-008-1 B/B	G9 max 1x40W	SD
OMI-008-1 B/B-S	T4/6 max 1x6W	SD

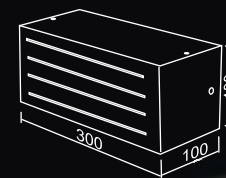

## OMI-008-2B/B

NB	⚡	WVK
OMI-008-2 B/B	G9 max 1x40W	SD
OMI-008-2 B/B-S	T4/6 max 1x6W	SD

NB - nr kat - cat.nr - Art.Nr  
⚡ - żarówka - bulb - Leuchtmittel  
WVK - wykończenie - finishing - Ausfuehrungen

SP - stal polerowana - polishing steel - Stahl poliert  
SD - stal drapana - scratched steel - Stahl gebuerstet

230V-50Hz IP20



# OMI-010

Oprawy ze stali nierdzewnej  
Stainless steel lamps  
Leuchten aus Edelstahl

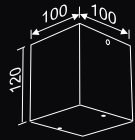

**OMI-010/B**

NR	Żarówka	WYK
OMI-010/B	GU10 max 1x50W	SD

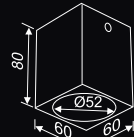

**OMI-010-1/1**

NR	Żarówka	WYK
OMI-010-1/1	GU10 max 1x50W	SD

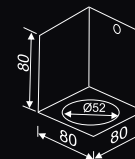

**OMI-010-1/2**

NR	Żarówka	WYK
OMI-010-1/2	GU10 max 1x50W	SD

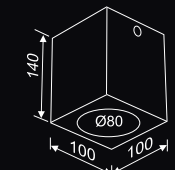

**OMI-010-1/3**

NR	Żarówka	WYK
OMI-010-1/3	Hi Spot80 max 1x75W	SD

NR - nr kat - cat.nr - Art.Nr

Żarówka - bulb - Leuchtmittel

WYK - wykończenie - finishing - Ausführungen

SP - stal polerowana - polishing steel - Stahl poliert

SD - stal drapana - scratched steel - Stahl gebuerstet

230V~50Hz IP20 CE



# OMI-013

Oprawy ze stali nierdzewnej  
Stainless steel lamps  
Leuchten aus Edelstahl

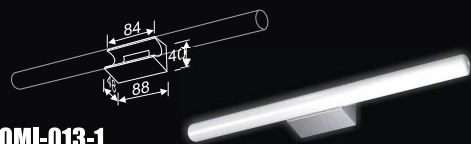

**OMI-013-1**

NR	💡	WVK
<b>OMI-013-1</b>	S14d max 1x60W	SD
<b>OMI-013-1-P</b>	S14d max 1x60W	SP

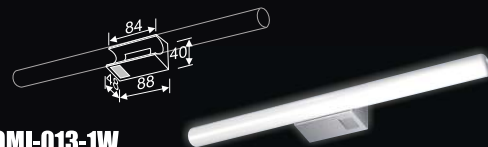

**OMI-013-1W**

NR	💡	WVK
<b>OMI-013-1W</b>	S14d max 1x60W	SD
<b>OMI-013-1W-P</b>	S14d max 1x60W	SP

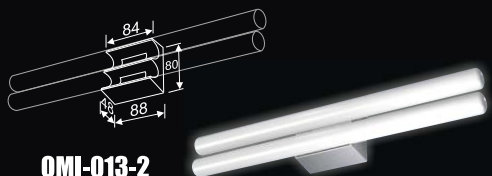

**OMI-013-2**

NR	💡	WVK
<b>OMI-013-2</b>	S14d max 2x60W	SD
<b>OMI-013-2-P</b>	S14d max 2x60W	SP

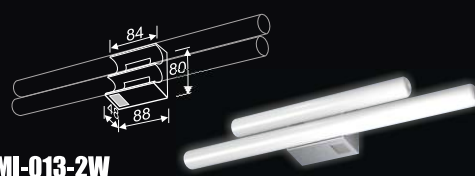

**OMI-013-2W**

NR	💡	WVK
<b>OMI-013-2W</b>	S14d max 2x60W	SD
<b>OMI-013-2W-P</b>	S14d max 2x60W	SP

żarówka Ralina (biała) 35W/230V (RA35), 60W/230V (RA60), także Linestra (Osram), Philinea (Philips)  
lub Kristallina (przezroczysta) 35W/230V (KR35), 60W/230V (KR60),  
bulb Ralina (white) 35W/230V (RA35), 60W/230V (RA60), also Linestra (Osram), Philinea (Philips)  
or Kristallina (transparent) 35W/230V (KR35), 60W/230V (KR60),  
Leuchtmittel Ralina (weiss) 35W/230V (RA35), 60W/230V (RA60), auch Linestra (Osram), Philinea (Philips)  
oder Kristallina (klar) 35W/230V (KR35), 60W/230V (KR60).



**OMI-013-3**

NR	💡	WVK
<b>OMI-013-3</b>	S14s max 1x120W	SD
<b>OMI-013-3-P</b>	S14s max 1x120W	SP

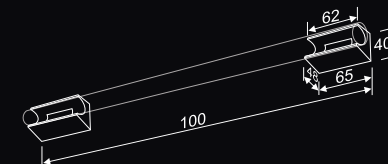

**OMI-013-4**

NR	💡	WVK
<b>OMI-013-4</b>	S14s max 2x120W	SD
<b>OMI-013-4-P</b>	S14s max 2x120W	SP

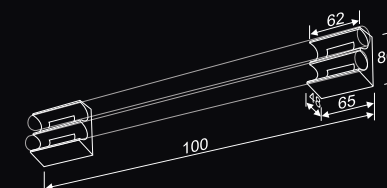

żarówka Ralina (biała) 120W/230V (RA 120), także Linestra (Osram), Philinea (Philips)  
lub Kristallina (przezroczysta) 120W/230V (KR 120),  
bulb Ralina (white) 120W/230V (RA 120), also Linestra (Osram), Philinea (Philips)  
or Kristallina (transparent) 120W/230V (KR 120),  
Leuchtmittel Ralina (weiss) 120W/230V (RA 120), auch Linestra (Osram), Philinea (Philips)  
oder Kristallina (klar) 120W/230V (KR 120).

NR - nr kat. - cat.nr - Art.Nr  
💡 - żarówka - bulb - Leuchtmittel  
WVK - wykończenie - finishing - Ausführungen  
SP - stal polerowana - polishing steel - Stahl poliert  
SD - stal drapana - scratched steel - Stahl gehuerstet

230V-50Hz IP20 CE



# OMI-014

Oprawy ze stali nierdzewnej  
Stainless steel lamps  
Leuchten aus Edelstahl



**OMI-014-2/230**

NR	Żarówka	WYK
OMI-014-2/230	GU10 max 2x35W	SD

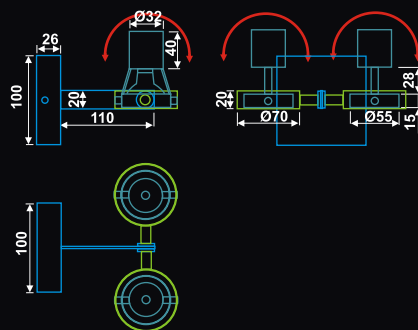

**OMI-014-1/12**

NR	Żarówka	WYK
OMI-014-1/12	HALOSPOT 111 G53 max 2x100W	SD

12V

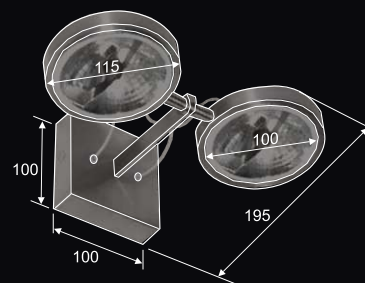

- NR - nr kat. • cat.nr • Art.Nr
- Żarówka • bulb • Leuchtmittel
- WYK - wykończenie • finishing • Ausfuehrungen
- SP - stal polerowana • polishing steel • Stahl poliert
- SD - stal drapana • scratched steel • Stahl gebuerstet

230V-50Hz IP20



# OMI-001

Oprawy ze stali nierdzewnej  
Stainless steel lamps  
Leuchten aus Edelstahl

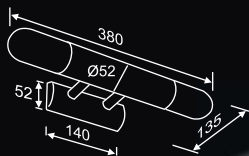

**OMI-001-1**

NR	Light	WWK
OMI - 001-1	E27 max 2x16W	SD
OMI - 001-1-P	E27 max 2x16W	SP

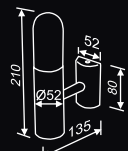
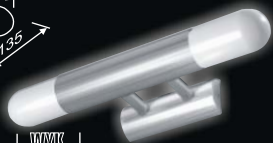

**OMI-001-2**

NR	Light	WWK
OMI - 001-2	E27 max 1x16W	SD
OMI - 001-2-P	E27 max 1x16W	SP

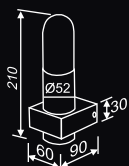

**OMI-001-2P**

NR	Light	WWK
OMI - 001-2P	E27 max 1x16W	SD
OMI - 001-2P-P	E27 max 1x16W	SP

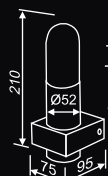

**OMI-001-2D**

NR	Light	WWK
OMI - 001-2D_	E27 max 1x16W	SD
OMI - 001-2D_-P	E27 max 1x16W	SP



drewno/ wood/ Holz  
- buk/ beech/ Buche (B)  
- dąb/ oak/ Eiche (D)



**OMI-001-3**

NR	Light	WWK
OMI - 001-3	E27 max 1x16W	SD
OMI - 001-3-P	E27 max 1x16W	SP

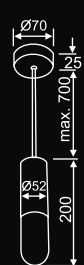

**OMI-001-5/1**

NR	Light	WWK
OMI - 001-5/1	E27 max 1x16W	SD
OMI - 001-5/1-P	E27 max 1x16W	SP

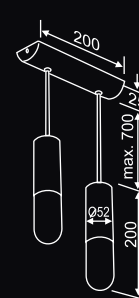

**OMI-001-5/2**

NR	Light	WWK
OMI - 001-5/2	E27 max 2x16W	SD
OMI - 001-5/2-P	E27 max 2x16W	SP

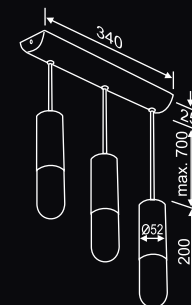

**OMI-001-5/3**

NR	Light	WWK
OMI - 001-5/3	E27 max 3x16W	SD
OMI - 001-5/3-P	E27 max 3x16W	SP

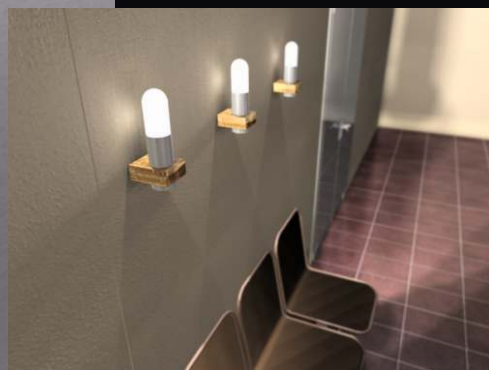

NR - nr kat - cat.nr - Art.Nr  
Light - żarówka - bulb - Leuchtmittel  
WWK - wykończenie - finishing - Ausfuehrungen  
SP - stal polerowana - polishing steel - Stahl poliert  
SD - stal drapaną - scratched steel - Stahl gebuerstet

230V~50Hz IP20 CE



# OMI-002

Oprawy ze stali nierdzewnej  
Stainless steel lamps  
Leuchten aus Edelstahl

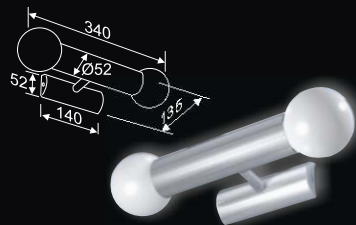

**OMI-002-1**

NR	Light bulb	WWK
OMI - 002-1	E27 G80 max 2x60W	SD
OMI - 002-1-P	E27 G80 max 2x60W	SP

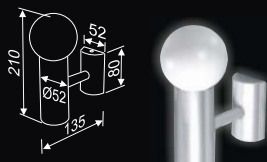

**OMI-002-2**

NR	Light bulb	WWK
OMI - 002-2	E27 G80 max 1x60W	SD
OMI - 002-2-P	E27 G80 max 1x60W	SP



**OMI-002-2P**

NR	Light bulb	WWK
OMI - 002-2P	E27 G80 max 1x60W	SD
OMI - 002-2P-P	E27 G80 max 1x60W	SP

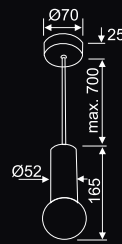

**OMI-002-5/1**

NR	Light bulb	WWK
OMI - 002-5/1	E27 G80 max 1x60W	SD
OMI - 002-5/1-P	E27 G80 max 1x60W	SP

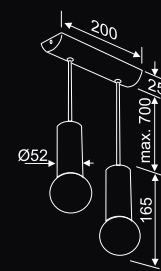

**OMI-002-5/2**

NR	Light bulb	WWK
OMI - 002-5/2	E27 G80 max 2x60W	SD
OMI - 002-5/2-P	E27 G80 max 2x60W	SP

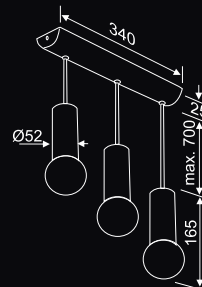

**OMI-002-5/3**

NR	Light bulb	WWK
OMI - 002-5/3	E27 G80 max 3x60W	SD
OMI - 002-5/3-P	E27 G80 max 3x60W	SP



**OMI-002-2D**

NR	Light bulb	WWK
OMI - 002-2D...	E27 G80 max 1x60W	SD
OMI - 002-2D...-P	E27 G80 max 1x60W	SP



**OMI-002-3**

NR	Light bulb	WWK
OMI - 002-3	E27 G80 max 1x60W	SD
OMI - 002-3-P	E27 G80 max 1x60W	SP



NR - nr kat. • cat.Nr. • Art.Nr  
Light bulb - żarówka • bulb • Leuchtmittel  
WWK - wykończenie • finishing • Ausfuehrungen

SP - stal polerowana • polishing steel • Stahl poliert  
SD - stal drapana • scratched steel • Stahl gebuerstet

230V~50Hz IP20



# OMI-003

Oprawy ze stali nierdzewnej  
Stainless steel lamps  
Leuchten aus Edelstahl

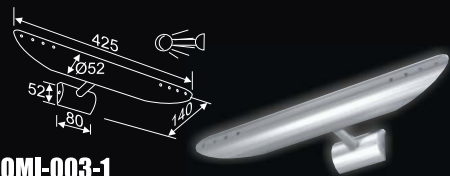

**OMI-003-1**

NR	Light bulb	WWK
OMI-003-1	G9 max 2x40W	SD
OMI-003-1-P	G9 max 2x40W	SP

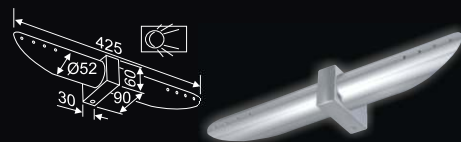

**OMI-003-1P**

NR	Light bulb	WWK
OMI-003-1P	G9 max 2x40W	SD
OMI-003-1P-P	G9 max 2x40W	SP

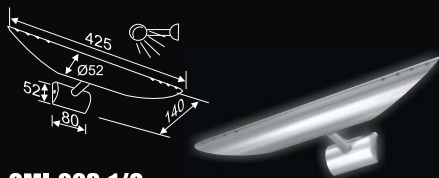

**OMI-003-1/0**

NR	Light bulb	WWK
OMI-003-1/0	G9 max 2x40W	SD
OMI-003-1/0-P	G9 max 2x40W	SP

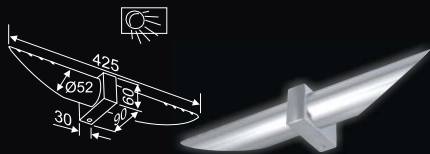

**OMI-003-1P/0**

NR	Light bulb	WWK
OMI-003-1P/0	G9 max 2x40W	SD
OMI-003-1P/0-P	G9 max 2x40W	SP

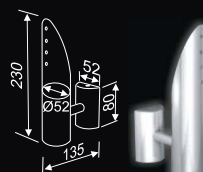

**OMI-003-2**

NR	Light bulb	WWK
OMI-003-2	G9 max 1x40W	SD
OMI-003-2-P	G9 max 1x40W	SP

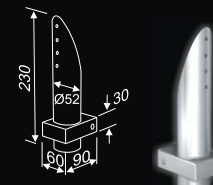

**OMI-003-2P**

NR	Light bulb	WWK
OMI-003-2P	G9 max 1x40W	SD
OMI-003-2P-P	G9 max 1x40W	SP

drewno/ wood/ Holz  
- buk/ beech/ Buche (B)  
- dąb/ oak/ Eiche (D)

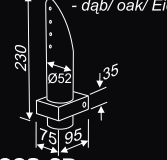

**OMI-003-2D**

NR	Light bulb	WWK
OMI-003-2D_	G9 max 1x35W	SD
OMI-003-2D_-P	G9 max 1x35W	SP

drewno/ wood/ Holz  
- buk/ beech/ Buche (B)  
- dąb/ oak/ Eiche (D)

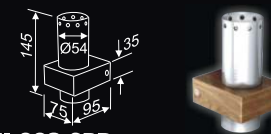

**OMI-003-2RD**

NR	Light bulb	WWK
OMI-003-2RD_	G9 max 1x35W	SD
OMI-003-2RD_-P	G9 max 1x35W	SP

NR - nr kat - cat.nr - Art.Nr

Light bulb - żarówka - bulb - Leuchtmittel

WWK - wykończenie - finishing - Ausfuehrungen

SP - stal polerowana - polishing steel - Stahl poliert

SD - stal drapana - scratched steel - Stahl gebuerstet

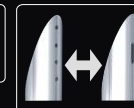

230V-50Hz IP20



# OMI-003

Oprawy ze stali nierdzewnej  
Stainless steel lamps  
Leuchten aus Edelstahl

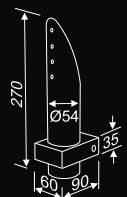

## OMI-003-2KS

NR	Light bulb	WWK
OMI - 003-2KS	G9 max 1x40W	SD
OMI - 003-2KS-P	G9 max 1x40W	SP

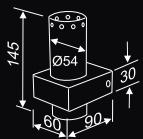
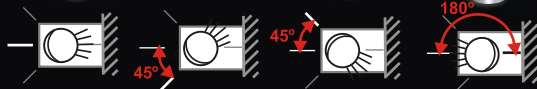

## OMI-003-2KP

NR	Light bulb	WWK
OMI - 003-2KP	GU10 max 1x50W	SD
OMI - 003-2KP-P	GU10 max 1x50W	SP



## OMI-003-3/1

NR	Light bulb	WWK
OMI - 003-3/1	GU10 max 1x50W	SD
OMI - 003-3/1-P	GU10 max 1x50W	SP



## OMI-003-3/2

NR	Light bulb	WWK
OMI - 003-3/2	GU10 max 1x50W	SD
OMI - 003-3/2-P	GU10 max 1x50W	SP

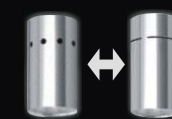

## OMI-003-3/3

NR	Light bulb	WWK
OMI - 003-3/3	HiSpot 80 max 1x75W	SD
OMI - 003-3/3-P	HiSpot 80 max 1x75W	SP

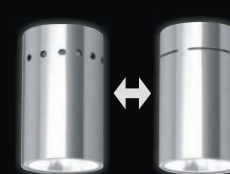

## OMI-003-3/4

NR	Light bulb	WWK
OMI - 003-3/4	GU10 max 1x50W	SD
OMI - 003-3/4-P	GU10 max 1x50W	SP

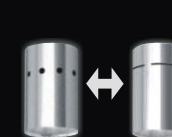

NR - nr kat. - cat.nr - Art.Nr  
 Light bulb - żarówka - bulb - Leuchtmittel  
 WWK - wykończenie - finishing - Ausführungen  
 SP - stal polerowana - polishing steel - Stahl poliert  
 SD - stal drapana - scratched steel - Stahl gebürstet



# OMI-003

Oprawy ze stali nierdzewnej  
Stainless steel lamps  
Leuchten aus Edelstahl

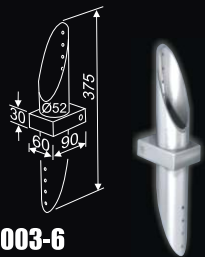

drewno/ wood/ Holzs  
- buk/ beech/ Buche (B)  
- dąb/ oak/ Eiche (D)

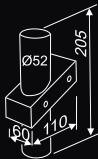

**OMI-003-6**

**OMI-003-6D**

**OMI-003-7**

NR	Light	WVK
OMI-003-6	G9 max 2x40W	SD
OMI-003-6-P	G9 max 2x40W	SP

NR	Light	WVK
OMI-003-6D_	G9 max 2x35W	SD
OMI-003-6D_-P	G9 max 2x35W	SP

NR	Light	WVK
OMI-003-7	G9 max 2x40W	SD
OMI-003-7-P	G9 max 2x40W	SP

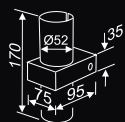
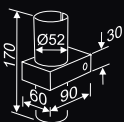

drewno/ wood/ Holzs  
- buk/ beech/ Buche (B)  
- dąb/ oak/ Eiche (D)

**OMI-003-8**

**OMI-003-8D**

NR	Light	WVK
OMI-003-8	G9 max 2x40W	SD
OMI-003-8-P	G9 max 2x40W	SP

NR	Light	WVK
OMI-003-8D_	G9 max 2x40W	SD
OMI-003-8D_-P	G9 max 2x40W	SP

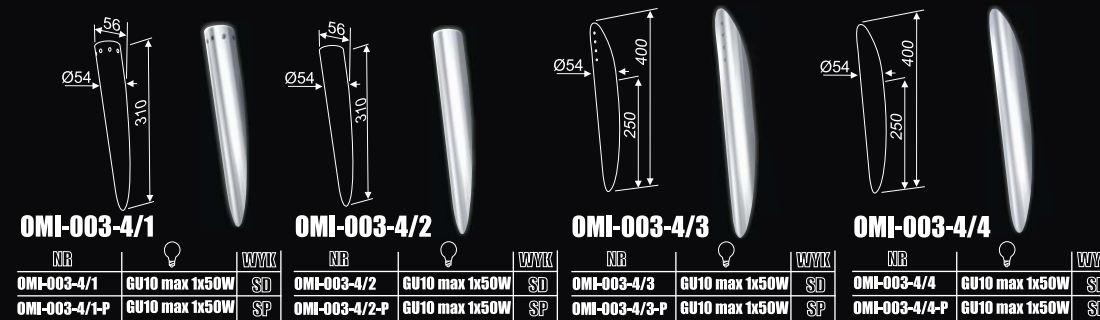

**OMI-003-4/1**

**OMI-003-4/2**

**OMI-003-4/3**

**OMI-003-4/4**

NR	Light	WVK
OMI-003-4/1	GU10 max 1x50W	SD
OMI-003-4/1-P	GU10 max 1x50W	SP

NR	Light	WVK
OMI-003-4/2	GU10 max 1x50W	SD
OMI-003-4/2-P	GU10 max 1x50W	SP

NR	Light	WVK
OMI-003-4/3	GU10 max 1x50W	SD
OMI-003-4/3-P	GU10 max 1x50W	SP

NR	Light	WVK
OMI-003-4/4	GU10 max 1x50W	SD
OMI-003-4/4-P	GU10 max 1x50W	SP



230V~50Hz IP20 CE



NR - nr kat. - cat.nr. - Art.Nr  
Light - żarówka - bulb - Leuchtmittel  
WVK - wykończenie - finishing - Ausführungen  
SP - stal polerowana - polishing steel - Stahl poliert  
SD - stal drapana - scratched steel - Stahl gebuerstet

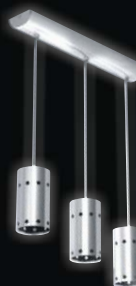
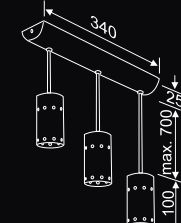
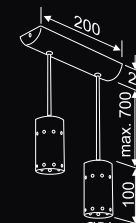
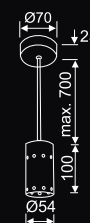
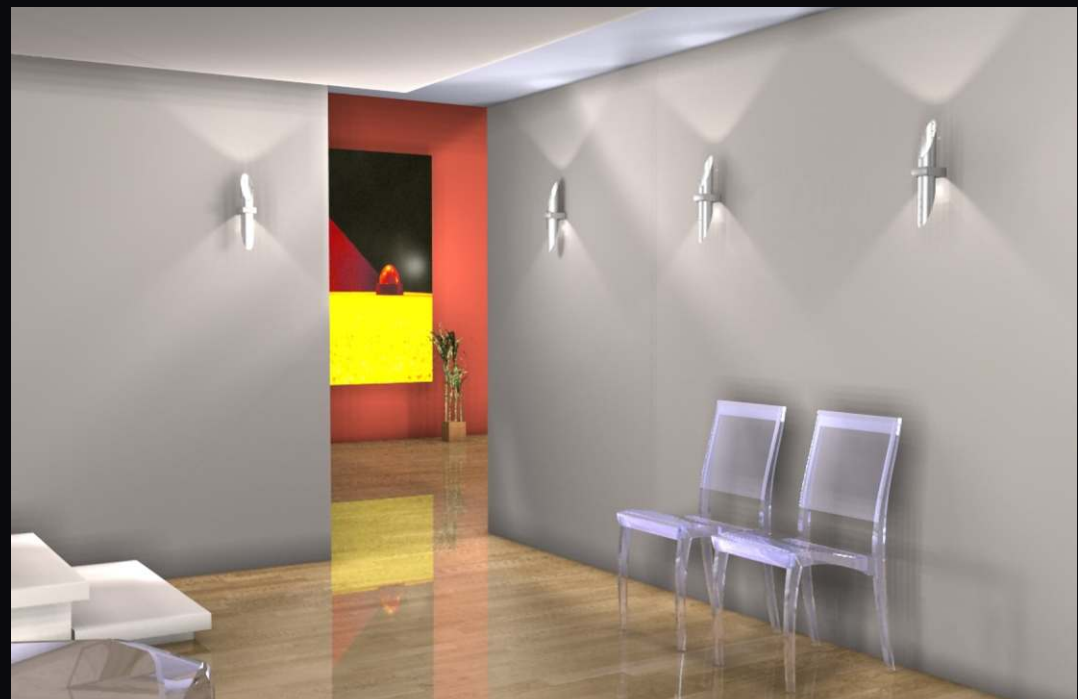

**OMI-003-5/1**

**OMI-003-5/2**

**OMI-003-5/3**

NR	Light	WVK
OMI-003-5/1	GU10 max 1x25W	SD
OMI-003-5/1-P	LED max 1x 25W	SP

NR	Light	WVK
OMI-003-5/2	GU10 max 2x25W	SD
OMI-003-5/2-P	LED max 2x 25W	SP

NR	Light	WVK
OMI-003-5/3	GU10 max 2x25W	SD
OMI-003-5/3-P	LED max 2x 25W	SP



# OMI-004

Oprawy ze stali nierdzewnej  
Stainless steel lamps  
Leuchten aus Edelstahl

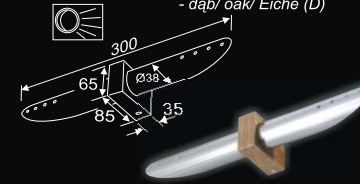
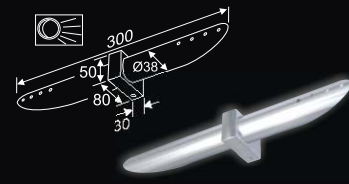
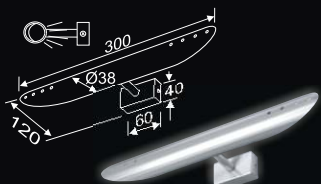

drewno/ wood/ Holzs  
- buk/ beech/ Buche (B)  
- dąb/ oak/ Eiche (D)

## OMI-004-1

## OMI-004-1P

## OMI-004-1D

NR	Light	WWK
OMI-004-1	G9 max 2x40W	SD
OMI-004-1-P	G9 max 2x40W	SP

NR	Light	WWK
OMI-004-1P	G9 max 2x40W	SD
OMI-004-1P-P	G9 max 2x40W	SP

NR	Light	WWK
OMI-004-1D	G9 max 2x35W	SD
OMI-004-1D-P	G9 max 2x35W	SP

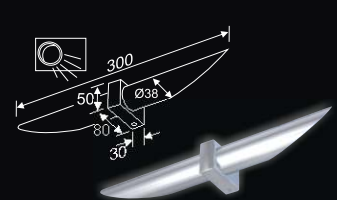
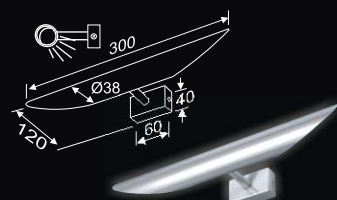

drewno/ wood/ Holzs  
- buk/ beech/ Buche (B)  
- dąb/ oak/ Eiche (D)

## OMI-004-1/O

## OMI-004-1P/O

## OMI-004-1D/O

NR	Light	WWK
OMI-004-1/O	G9 max 2x40W	SD
OMI-004-1/O-P	G9 max 2x40W	SP

NR	Light	WWK
OMI-004-1P/O	G9 max 2x40W	SD
OMI-004-1P/O-P	G9 max 2x40W	SP

NR	Light	WWK
OMI-004-1D_/O	G9 max 2x35W	SD
OMI-004-1D_/O-P	G9 max 2x35W	SP

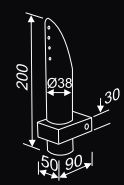
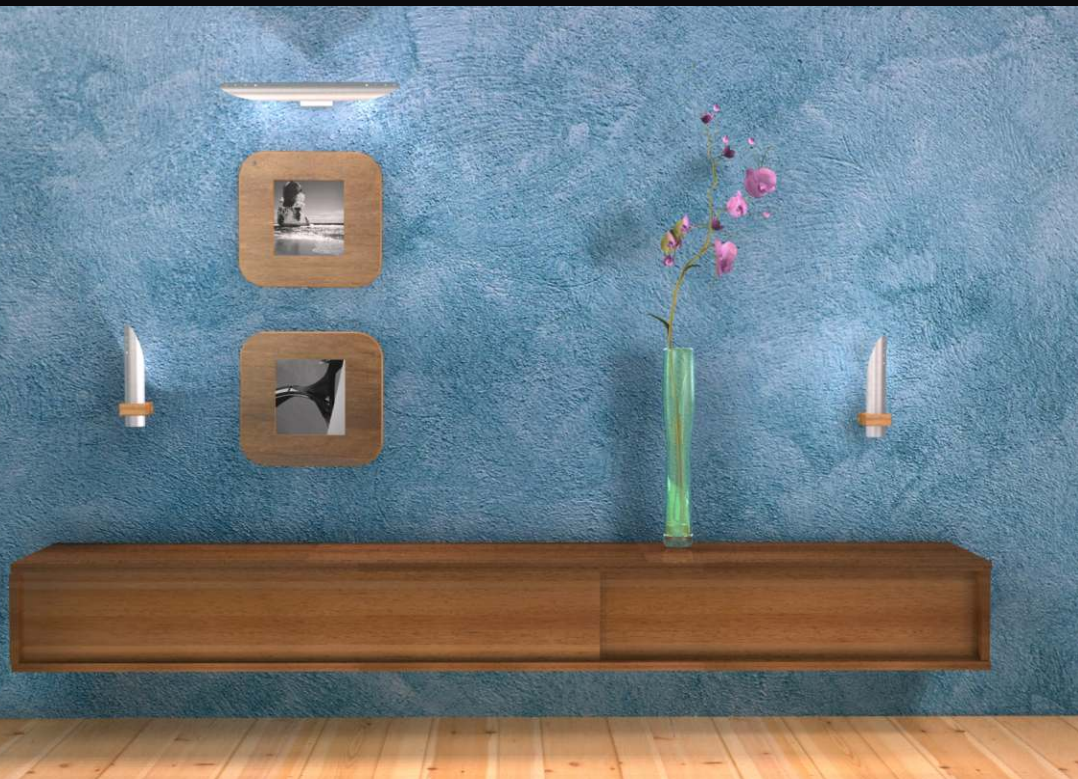

## OMI-004-2

NR	Light	WWK
OMI-004-2	G9 max 2x40W	SD
OMI-004-2-P	G9 max 2x40W	SP



## OMI-004-2-45P

NR	Light	WWK
OMI-004-2-45P	G9 max 1x40W	SD
OMI-004-2-45P-P	G9 max 1x40W	SP



## OMI-004-2-45L

NR	Light	WWK
OMI-004-2-45L	G9 max 1x40W	SD
OMI-004-2-45L-P	G9 max 1x40W	SP

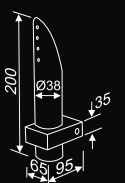

## OMI-004-2D

NR	Light	WWK
OMI-004-2D	G9 max 1x35W	SD
OMI-004-2D-P	G9 max 1x35W	SP

drewno/ wood/ Holzs  
- buk/ beech/ Buche (B)  
- dąb/ oak/ Eiche (D)



## OMI-004-2D-45P

NR	Light	WWK
OMI-004-2D-45P	G9 max 1x35W	SD
OMI-004-2D-45P-P	G9 max 1x35W	SP

drewno/ wood/ Holzs  
- buk/ beech/ Buche (B)  
- dąb/ oak/ Eiche (D)



## OMI-004-2D-45L

NR	Light	WWK
OMI-004-2D-45L	G9 max 1x35W	SD
OMI-004-2D-45L-P	G9 max 1x35W	SP

NR - nr kat - cat.nr - Art.Nr  
Light - żarówka - bulb - Leuchtmittel

WWK - wykończenie - finishing - Ausfuehrungen  
SD - stal polerowana - polishing steel - Stahl poliert  
SP - stal drapana - scratched steel - Stahl gebuerstet



230V - 50Hz IP20 CE



# OMI-004

Oprawy ze stali nierdzewnej  
Stainless steel lamps  
Leuchten aus Edelstahl

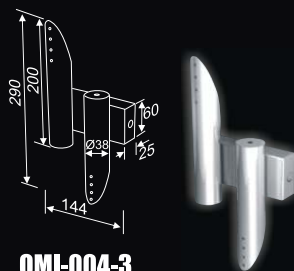

**OMI-004-3**

NR	Light	WWK
OMI-004-3	G9 max 2x40W	SD
OMI-004-3-P	G9 max 2x40W	SP



**OMI-004-3D**

NR	Light	WWK
OMI-004-3D_	G9 max 2x35W	SD
OMI-004-3D_-P	G9 max 2x35W	SP

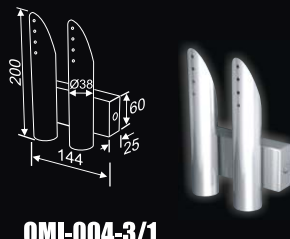

**OMI-004-3/1**

NR	Light	WWK
OMI-004-3/1	G9 max 2x40W	SD
OMI-004-3/1-P	G9 max 2x40W	SP

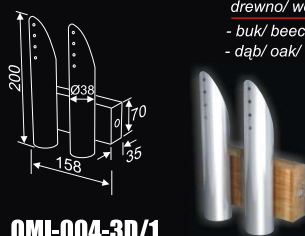

**OMI-004-3D/1**

NR	Light	WWK
OMI-004-3D_/1	G9 max 2x35W	SD
OMI-004-3D_/1-P	G9 max 2x35W	SP

drewno/ wood/ Holz  
- buk/ beech/ Buche (B)  
- dąb/ oak/ Eiche (D)

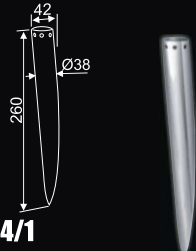

**OMI-004-4/1**

NR	Light	WWK
OMI-004-4/1	G9 max 1x40W	SD
OMI-004-4/1-P	G9 max 1x40W	SP

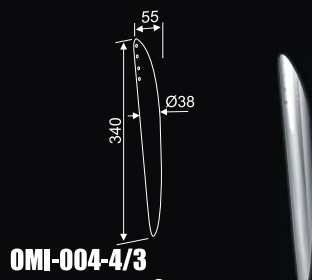

**OMI-004-4/3**

NR	Light	WWK
OMI-004-4/3	G9 max 1x40W	SD
OMI-004-4/3-P	G9 max 1x40W	SP

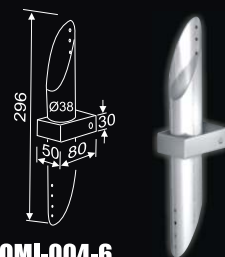
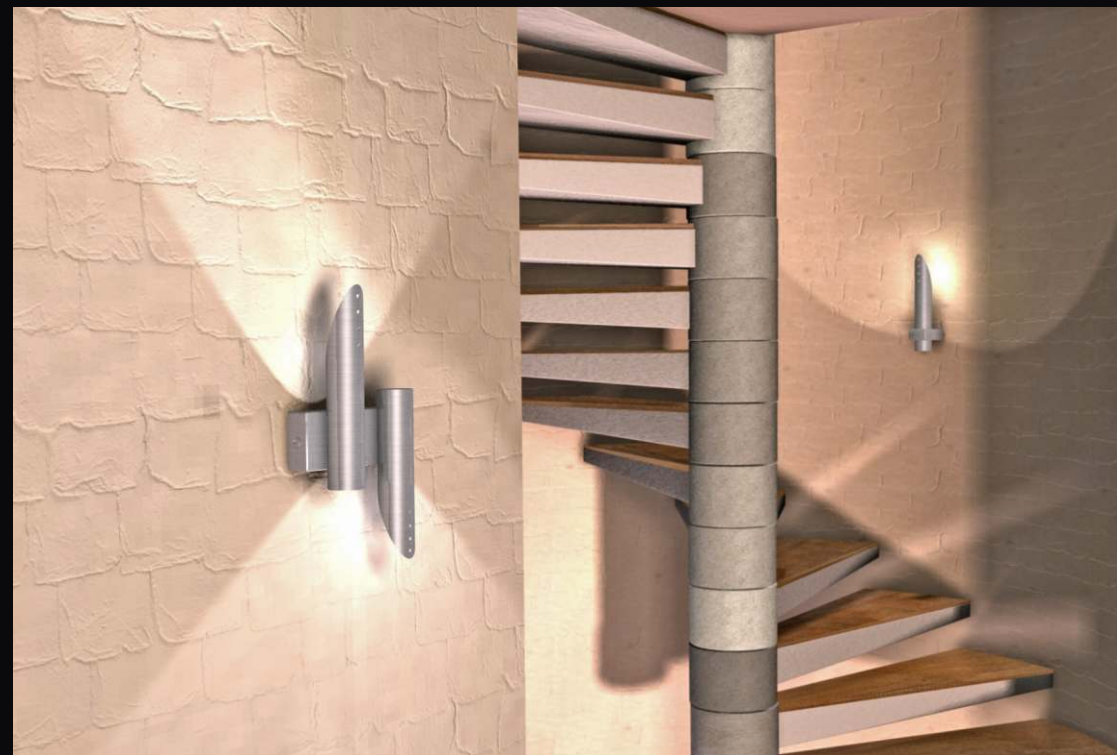

**OMI-004-6**

NR	Light	WWK
OMI-004-6	G9 max 2x40W	SD
OMI-004-6-P	G9 max 2x40W	SP



**OMI-004-6D**

NR	Light	WWK
OMI-004-6D_	G9 max 2x35W	SD
OMI-004-6D_-P	G9 max 2x35W	SP

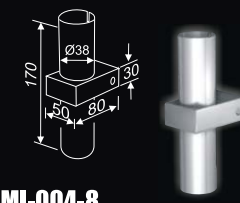

**OMI-004-8**

NR	Light	WWK
OMI-004-8	G9 max 2x40W	SD
OMI-004-8-P	G9 max 2x40W	SP

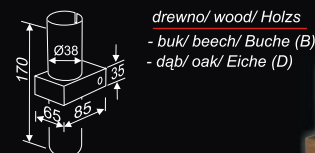

**OMI-004-8D**

NR	Light	WWK
OMI-004-8D_	G9 max 2x35W	SD
OMI-004-8D_-P	G9 max 2x35W	SP



NR - nr kat. cat.nr. Art.Nr  
Light - żarówka - bulb - Leuchtmittel  
WWK - wykończenie - finishing - Ausführungen  
SP - stal polerowana - polishing steel - Stahl poliert  
SD - stal drapaną - scratched steel - Stahl gebürstet

# OMI-005

Oprawy ze stali nierdzewnej  
Stainless steel lamps  
Leuchten aus Edelstahl

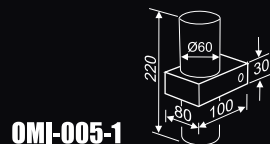

**OMI-005-1**

NR	Light bulb	WYK
OMI-005-1	G9 max 2x40W	SD
OMI-005-1-P	G9 max 2x40W	SP



drewno/ wood/ Holzs  
- buk/ beech/ Buche (B)  
- dąb/ oak/ Eiche (D)

**OMI-005-1D**

NR	Light bulb	WYK
OMI-005-1D_	G9 max 2x35W	SD
OMI-005-1D_-P	G9 max 2x35W	SP

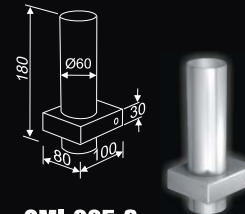
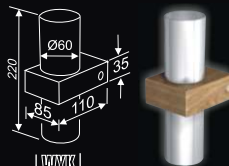

**OMI-005-3**

NR	Light bulb	WYK
OMI-005-3	G9 max 1x40W	SD
OMI-005-3-P	G9 max 1x40W	SP



drewno/ wood/ Holzs  
- buk/ beech/ Buche (B)  
- dąb/ oak/ Eiche (D)

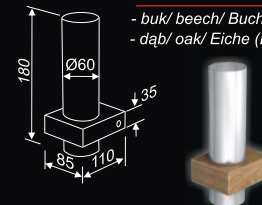

**OMI-005-3D**

NR	Light bulb	WYK
OMI-005-3D_	G9 max 1x35W	SD
OMI-005-3D_-P	G9 max 1x35W	SP

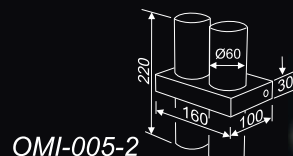

**OMI-005-2**

NR	Light bulb	WYK
OMI-005-2	4x G9 40W	SD
OMI-005-2-P	4x G9 40W	SP



drewno/ wood/ Holzs  
- buk/ beech/ Buche (B)  
- dąb/ oak/ Eiche (D)

**OMI-005-2D**

NR	Light bulb	WYK
OMI-005-2D_	4x G9 35W	SD
OMI-005-2D_-P	4x G9 35W	SP

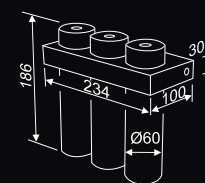
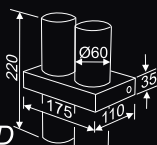

**OMI-005-5**

NR	Light bulb	WYK
OMI-005-5	G9 max 3x40W	SD
OMI-005-5-P	G9 max 3x40W	SP

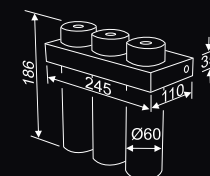

**OMI-005-5D**

NR	Light bulb	WYK
OMI-005-5D_	G9 max 3x35W	SD
OMI-005-5D_-P	G9 max 3x35W	SP



drewno/ wood/ Holzs  
- buk/ beech/ Buche (B)  
- dąb/ oak/ Eiche (D)

NR - nr kat - cat.nr - Art.Nr

Light bulb - żarówka - bulb - Leuchtmittel

WYK - wykończenie - finishing - Ausführungen

SP - stal polerowana - polishing steel - Stahl poliert

SD - stal drapana - scratched steel - Stahl geuberstet

230V- 50Hz IP20 CE



# OMI-011

Oprawy ze stali nierdzewnej  
Stainless steel lamps  
Leuchten aus Edelstahl

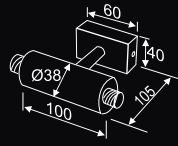

**OMI-0011-1**

NR	💡	WYK
OMI-011-1/_	G9 max 2x40W	SD
OMI-011-1/_-P	G9 max 2x40W	SP

KL:  
-1  
-2  
-3  
-4

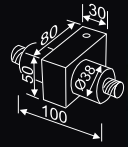

**OMI-0011-1P**

NR	💡	WYK
OMI-011-1P/_	G9 max 2x40W	SD
OMI-011-1P/_-P	G9 max 2x40W	SP

KL:  
-1  
-2  
-3  
-4

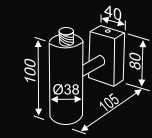

**OMI-0011-2**

NR	💡	WYK
OMI-011-2/_	G9 max 1x40W	SD
OMI-011-2/_-P	G9 max 1x40W	SP

KL:  
-1  
-2  
-3  
-4

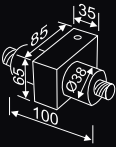

**OMI-0011-1D**

NR	💡	WYK
OMI-011-1D/_	G9 max 2x35W	SD
OMI-011-1D/_-P	G9 max 2x35W	SP

KL:  
-1  
-2  
-3  
-4



drewno/ wood/ Holzs  
- buk/ beech/ Buche (B)  
- dąb/ oak/ Eiche (D)



**OMI-0011-1L**

NR	💡	WYK
OMI-011-1L/_	G9 max 2x40W	SD
OMI-011-1L/_-P	G9 max 2x40W	SP

KL:  
-1  
-2  
-3  
-4

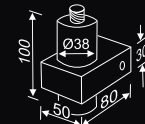

**OMI-0011-2P**

NR	💡	WYK
OMI-011-2P/_	G9 max 1x40W	SD
OMI-011-2P/_-P	G9 max 1x40W	SP

KL:  
-1  
-2  
-3  
-4

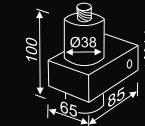

**OMI-0011-2D**

NR	💡	WYK
OMI-011-2D/_	G9 max 1x35W	SD
OMI-011-2D/_-P	G9 max 1x35W	SP

KL:  
-1  
-2  
-3  
-4



drewno/ wood/ Holzs  
- buk/ beech/ Buche (B)  
- dąb/ oak/ Eiche (D)



**OMI-011-2L**

NR	💡	WYK
OMI-011-2L/_	G9 max 1x40W	SD
OMI-011-2L/_-P	G9 max 1x40W	SP

KL:  
-1  
-2  
-3  
-4

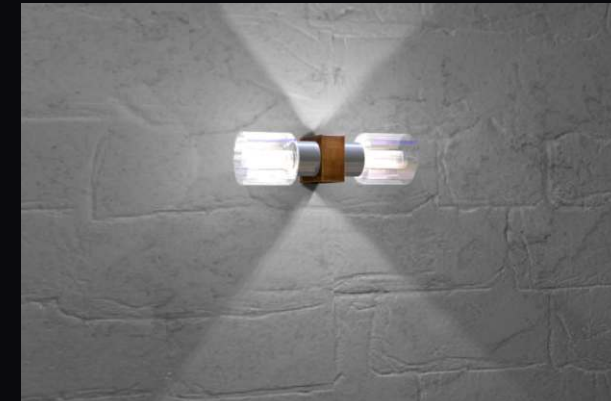

- NR - nr kat - cat.Nr - Art.Nr
- 💡 - żarówka - bulb - Leuchtmittel
- WYK - wykończenie - finishing - Ausfuehrungen
- SP - stal polerowana - polishing steel - Stahl poliert
- SD - stal drapana - scratched steel - Stahl gebuerstet

230V-50Hz IP20 CE

KL - klosze szklane - glass lampshades - Glasschirm

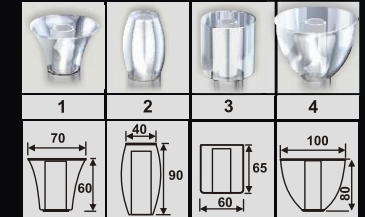

# OMI-011

Oprawy ze stali nierdzewnej  
Stainless steel lamps  
Leuchten aus Edelstahl

drewno/ wood/ Holz  
- buk/ beech/ Buche (B)  
- dąb/ oak/ Eiche (D)

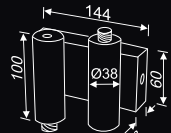

**OMI-011-3**

NR	Light bulb	WVK
OMI-011-3/_	G9 max 2x40W	SD
OMI-011-3/_-P	G9 max 2x40W	SP



KL:  
-1  
-2  
-3

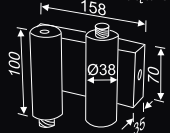

**OMI-011-3D**

NR	Light bulb	WVK
OMI-011-3D/_	G9 max 2x35W	SD
OMI-011-3D/_-P	G9 max 2x35W	SP



KL:  
-1  
-2  
-3  
-4

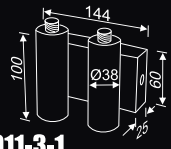

**OMI-011-3-1**

NR	Light bulb	WVK
OMI-011-3-1/_	G9 max 2x40W	SD
OMI-011-3-1/_-P	G9 max 2x40W	SP



KL:  
-1  
-2  
-3

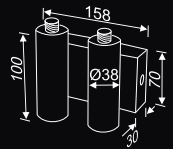

**OMI-011-3-1D**

NR	Light bulb	WVK
OMI-011-3-1D/_	G9 max 2x35W	SD
OMI-011-3-1D/_-P	G9 max 2x35W	SP



KL:  
-1  
-2  
-3  
-4

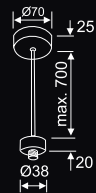
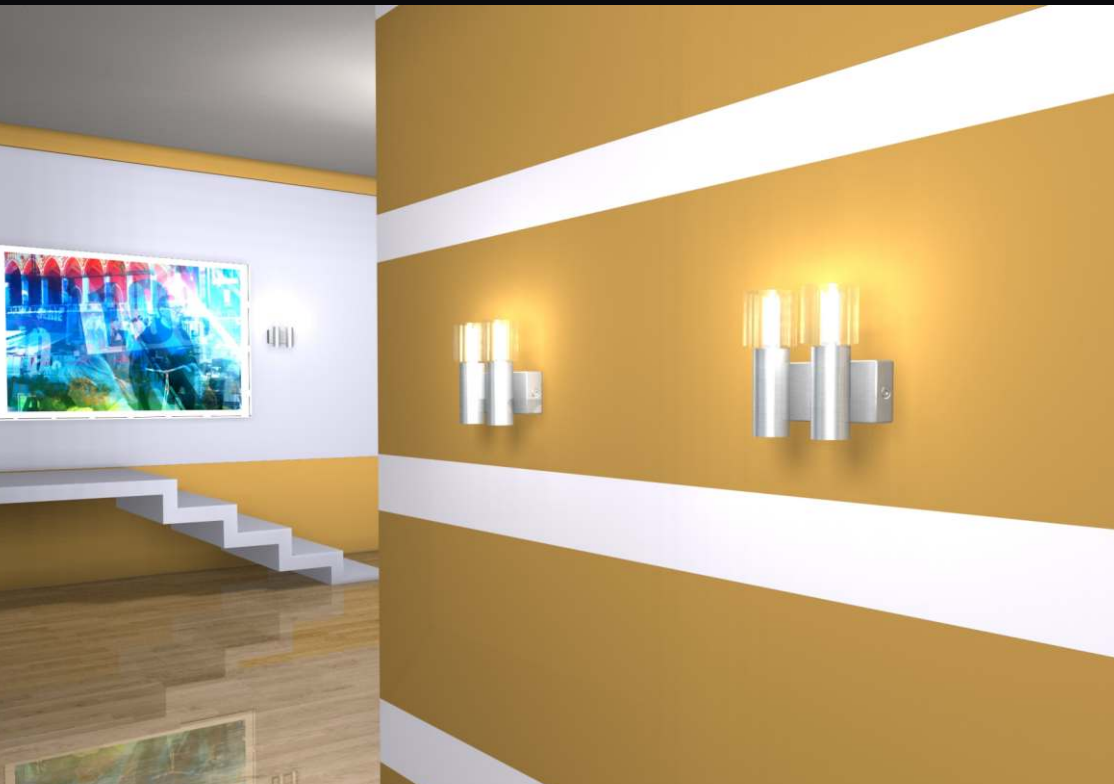

**OMI-011-5-1**

NR	Light bulb	WVK
OMI-011-5-1/_	G9 max 1x25W	SD
OMI-011-5-1/_-P	G9 max 1x25W	SP



KL:  
-1  
-2  
-3  
-4

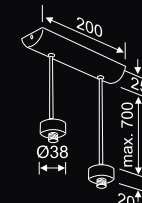

**OMI-011-5-2**

NR	Light bulb	WVK
OMI-011-5-2/_	G9 max 2x25W	SD
OMI-011-5-2/_-P	G9 max 2x25W	SP



KL:  
-1  
-2  
-3  
-4

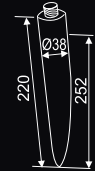

**OMI-011-4/2**

NR	Light bulb	WVK
OMI-011-4/2	G9 max 1x40W	SD
OMI-011-4/2-P	G9 max 1x40W	SP



KL:  
-2

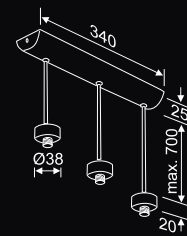

**OMI-0011-5-3**

NR	Light bulb	WVK
OMI-011-5-3/_	G9 max 3x25W	SD
OMI-011-5-3/_-P	G9 max 3x25W	SP



KL:  
-1  
-2  
-3  
-4

KL - klosze szklane • glass lampshades • Glasschirm

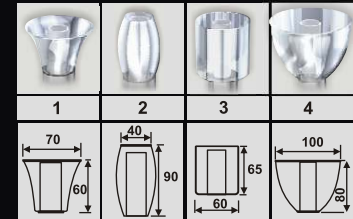

230V-50Hz  
IP20  
CE

NR - nr kat • cat.nr • Art.Nr  
Light bulb - żarówka • bulb • Leuchtmittel  
WVK - wykończenie • finishing • Ausfuehrungen  
SP - stal polerowana • polishing steel • Stahl poliert  
SD - stal drapana • scratched steel • Stahl gebuerstet



# OMI-012

Oprawy ze stali nierdzewnej  
Stainless steel lamps  
Leuchten aus Edelstahl



OMI-012-1

NR	Light	WWK
OMI-012-1/_	G9 max 2x40W	SD
OMI-012-1/_-P	G9 max 2x40W	SP

KL:  
-3  
-4



OMI-012-1P

NR	Light	WWK
OMI-012-1P/_	G9 max 2x40W	SD
OMI-012-1P/_-P	G9 max 2x40W	SP

KL:  
-3  
-4



OMI-012-1D

NR	Light	WWK
OMI-012-1D/_	G9 max 2x35W	SD
OMI-012-1D/_-P	G9 max 2x35W	SP

KL:  
-3  
-4

drewno/ wood/ Holz  
- buk/ beech/ Buche (B)  
- dąb/ oak/ Eiche (D)

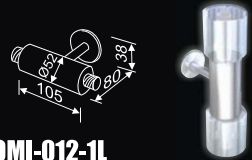

OMI-012-1L

NR	Light	WWK
OMI-012-1L/_	G9 max 2x40W	SD
OMI-012-1L/_-P	G9 max 2x40W	SP

KL:  
-3  
-4

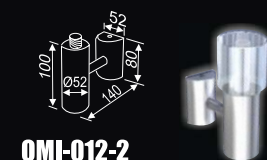

OMI-012-2

NR	Light	WWK
OMI-012-2/_	G9 max 1x40W	SD
OMI-012-2/_-P	G9 max 1x40W	SP

KL:  
-3  
-4



OMI-012-2P

NR	Light	WWK
OMI-012-2P/_	G9 max 1x40W	SD
OMI-012-2P/_-P	G9 max 1x40W	SP

KL:  
-3  
-4



OMI-012-2L

NR	Light	WWK
OMI-012-2L/_	G9 max 2x40W	SD
OMI-012-2L/_-P	G9 max 2x40W	SP

KL:  
-3  
-4



OMI-012-2D

NR	Light	WWK
OMI-012-2D/_	G9 max 2x40W	SD
OMI-012-2D/_-P	G9 max 2x40W	SP

KL:  
-3  
-4

drewno/ wood/ Holz  
- buk/ beech/ Buche (B)  
- dąb/ oak/ Eiche (D)

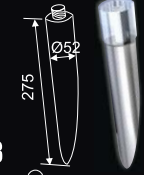

OMI-012-4/3

NR	Light	WWK
OMI-012-4/3_	G9 max 1x40W	SD
OMI-012-4/3_-P	G9 max 1x40W	SP

KL:  
-3



OMI-012-5-1

NR	Light	WWK
OMI-012-5-1/_	G9 max 1x25W	SD
OMI-012-5-1/_-P	G9 max 1x25W	SP

KL:  
-3  
-4



OMI-012-5-2

NR	Light	WWK
OMI-012-5-2/_	G9 max 2x25W	SD
OMI-012-5-2/_-P	G9 max 2x25W	SP

KL:  
-3  
-4



OMI-012-5-3

NR	Light	WWK
OMI-012-5-3/_	G9 max 3x25W	SD
OMI-012-5-3/_-P	G9 max 3x25W	SP

KL:  
-3  
-4

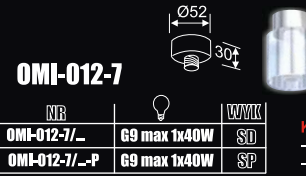

OMI-012-7

NR	Light	WWK
OMI-012-7/_	G9 max 1x40W	SD
OMI-012-7/_-P	G9 max 1x40W	SP

KL:  
-3  
-4

NR - nr kat. - cat.nr. - Art.Nr  
Light - żarówka - bulb - Leuchtmittel  
WWK - wykończenie - finishing - Ausfuehrungen  
SP - stal polerowana - polishing steel - Stahl poliert  
SD - stal drapana - scratched steel - Stahl gebuerstet

230V - 50Hz IP20



KL - klosze szklane  
glass lampshades  
Glasschirm

3

4



# OMI

Żarówki do OMI  
Bulbs to OMI  
Birne in OMI

NR		WYK
	G9 max 1x40W	SD
	G9 max 1x40W	SP

żarówka/ bulb/ Energiesparlampen  
E-27 16W/230-240V

NR  
ZA-Philips

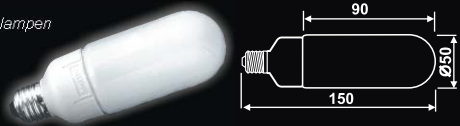

żarówka/ bulb/ Birne  
GLOB-G80 60W/230V

NR  
ZA-Kula

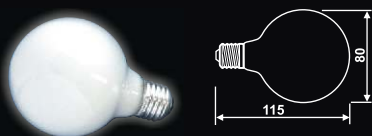

żarówka/ bulb/ Halogenlampe  
GU10 25 lub 50W/230V  
GU10 25 or 50W/230V  
GU10 25 oder 50W/230V

NR  
ZA-GU10/\_

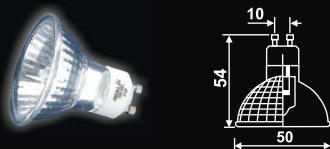

żarówka/ bulb/ Halogenlampe  
G9 35 lub 40W/230V  
G9 35 or 40W/230V  
G9 35 oder 40W/230V

NR  
ZA-G9/\_



żarówka/ bulb/ Leuchtmittel  
GU10 LED 1.8W/220-240V

NR  
ZA-LED/\_

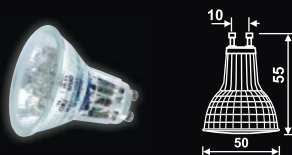

kolor/ colour/ Farben  
biały/ white/ weiss (BI)  
niebieski/ blue/ blau (NI)  
zielony/ green/ gruen (ZI)  
czerwony/ red/ rot (CZ)  
pomarańczowy/ orange (PO)

żarówka/ bulb/ Leuchtmittel  
Hi Spot 80 75W/230V

NR  
ZA-Hi Spot 80

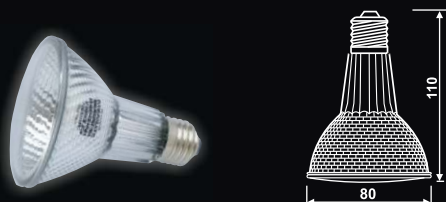

RALINA  
KRISTALLINA

NR	K	
RA35, RA65	BI	35W, 60W
KR35, KR65	PR	35W, 60W

KRISTALLINA (przezroczysta/ transparent/ klar)

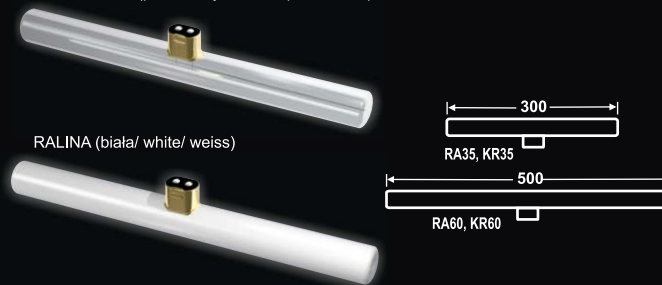

RALINA (biała/ white/ weiss)

RALINA  
KRISTALLINA

NR	K	
RA120	BI	120W
KR120	PR	120W

KRISTALLINA (przezroczysta/ transparent/ klar)



RALINA (biała/ white/ weiss)



NR - nr kat. · cat.nr · Art.Nr  
 - żarówka · bulb · Leuchtmittel  
 K - kolor · colour · Farben  
 BI - biały · white · weiss  
 PR - przezroczysty · transparent · klar